

TECHNICAL MANUAL

OPERATOR'S AND UNIT MAINTENANCE MANUAL
(INCLUDING REPAIR PARTS AND
SPECIAL TOOLS LISTS)

SPACE HEATER SMALL
(NSN 4520-01-478-9207)



DISTRIBUTION STATEMENT A – Approved for public release; distribution is unlimited.

HEADQUARTERS, DEPARTMENT OF THE ARMY

15 NOVEMBER 2001

THIS PAGE INTENTIONALLY LEFT BLANK

WARNING SUMMARY

This warning summary contains general safety warnings and hazardous materials warnings that must be understood and applied during operation of this equipment. Failure to observe these precautions could result in serious injury or death to personnel. Also included are explanations of safety and hazardous materials icons used within this technical manual.

EXPLANATION OF SAFETY WARNING ICONS



CARBON MONOXIDE – human figure showing gaseous substance being inhaled into respiratory system, demonstrating potential hazard.



EXPLOSION - rapidly expanding symbol shows that the material may explode if subjected to high temperatures, sources of ignition, or high pressure.



FIRE - flame shows that a material may ignite and cause burns.



HOT AREA - hand over object radiating heat shows that part is hot and can burn.



CRYOGENIC - hand in block of ice shows that the material is extremely cold and can injure human skin or tissue.



CHEMICAL - drops of liquid on hand shows that the material will cause burns or irritation to human skin or tissue.



POISON - skull and crossbones shows that a material is poisonous or is a danger to life.



SHARP OBJECT - pointed object in hand shows that a sharp object presents a danger to limb.

GENERAL SAFETY WARNINGS DESCRIPTION



WARNING

During operation, the Space Heater Small (SHS) produces harmful carbon monoxide (CO) and other gases. Carbon monoxide is a colorless, odorless, and tasteless gas. Mild cases of carbon monoxide poisoning can cause symptoms such as nausea, dizziness or headaches. Severe cases of carbon monoxide poisoning can result in brain damage, heart damage or death. Remember that although CO has no telltale odor, it may mix with other odors which mask its presence; therefore, CO can be present within a mix of seemingly harmless odors.

To prevent CO poisoning, ensure that the SHS exhaust stack sections fit together snugly and that the exhaust gases are properly vented through the roof of the shelter.

The best way to prevent CO poisoning is to keep the SHS in good working order. Ensure that all possible sources of CO leakage have been repaired and that the operating space is well ventilated.



WARNING

Do not touch cold metal parts with bare hands. Frostbite can cause permanent injury to personnel.



WARNING



Fuels are toxic and flammable. Wear protective goggles and refuel only in a well-ventilated area. Avoid contact with skin, eyes, and clothes and don't breathe vapors. Do not use near open flame or excessive heat. If you become dizzy, get fresh air immediately and get medical aid. If contact with eyes or skin is made, immediately flush with clean water and get medical aid for eyes immediately.



WARNING

Do not use unauthorized fuels! Use of unauthorized fuel may result in fire/explosion!



Tent exhaust opening closure flap must be rolled and tied securely. Tent may catch fire if hot stack assembly contacts the flap.

Poorly fitted stack sections may allow hot stack to fall on tent and start a fire, or deadly carbon monoxide to leak into tent. Ensure sections seat together fully and that rain cap assembly is securely fastened to the appropriate "D" rings on the tent stake strap.

For safe operation, be sure to allow at least one (1) foot (30 cm) of space between the base of the heater and the bottom of the tent wall. Never relight a extinguished flame while the heater is hot. Be sure to allow the heater to cool completely before attempting to relight. Do not attempt to replenish the fuel supply while the heater is in operation. Be certain that there is no open flame in the vicinity of liquid fuel.

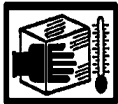

WARNING

Severe injury may occur to personnel handling metal parts without protective gloves when temperatures are below freezing. Skin may freeze upon contact and tear from the flesh.

Do not allow fuel to come in contact with bare skin. Even though fuel does not freeze, it is extremely cold and will burn exposed skin on contact. Wear protective gloves whenever handling or working with liquid fuel.



WARNING

Do not attempt to handle or perform services on an SHS that has recently been in operation. Let the space heater cool down before performing these procedures to avoid the possibility of serious burns.



WARNING

Some metal components of SHS may have sharp edges. Be careful when handling and assembling the SHS to prevent cuts.

THIS PAGE INTENTIONALLY LEFT BLANK

TM 10-4520-263-12&P

INSERT LATEST CHANGED PAGES / WORK PACKAGES. DESTROY SUPERSEDED DATA

LIST OF EFFECTIVE PAGES / WORK PACKAGES

NOTE: The portion of text affected by the changes is indicated by a vertical line in the outer margins of the page. Changes to illustrations are indicated by miniature pointing hands. Changes to wiring diagrams are indicated by shaded areas.

Dates of issue for original and changed pages / work packages are:

Original .. 0 ..15 Nov 01

TOTAL NUMBER OF PAGES FOR FRONT AND REAR MATTER IS 24 AND TOTAL NUMBER OF WORK PACKAGES IS 50 CONSISTING OF THE FOLLOWING:

Page / WP* No.	Change No.	Page / WP No.	*Change No.	Page / WP No.	*Change No.
Title	0				
a-d	0				
A-B	0				
i-iv	0				
WP 0001 00 – 0050 00	0				
Index 1 – Index 4	0				

*Zero in this column indicates an original page or work package

A/(B blank)

THIS PAGE INTENTIONALLY LEFT BLANK

TM 10-4520-263-12&P

HEADQUARTERS
DEPARTMENT OF THE ARMY
WASHINGTON, D.C., 15 NOVEMBER 2001

TECHNICAL MANUAL

**OPERATOR'S AND UNIT MAINTENANCE MANUAL
(INCLUDING REPAIR PARTS AND SPECIAL TOOLS LISTS)**

SPACE HEATER SMALL (SHS)

(NSN 4520-01-478-9207)

REPORTING ERRORS AND RECOMMENDING IMPROVEMENTS

You can help improve this manual. If you find any mistakes or if you know of a way to improve the procedures, please let us know. Mail your letter together with DA Form 2028 (Recommended Changes to Publications and Blank Forms), located in the back of this manual, directly to: Commander, U.S. Army Soldier and Biological Chemical Command, ATTN: AMSSB-RIM-E(N), Kansas Street, Natick, MA 01760-5052. You may also send in your recommended changes via electronic mail directly to amssb-rim-e@natick-army.mil. A reply will be furnished to you. Instructions for sending an electronic 2028 may be found at the back of this manual immediately preceding the hard copy 2028.

DISTRIBUTION STATEMENT A – Approved for public release. Distribution is unlimited.

TABLE OF CONTENTS

WP Sequence No.

WARNING SUMMARY

HOW TO USE THIS MANUAL

Scope.....	0001 00
Maintenance Forms Records And Reports	0001 00
Reporting Equipment Improvement Recommendations (EIRS).....	0001 00
Corrosion Prevention And Control (CPC).....	0001 00
Destruction Of Army Materiel To Prevent Enemy Use	0001 00
Nomenclature Cross-Reference List	0001 00
List Of Abbreviations/Acronyms	0001 00
Safety, Care And Handling, Warnings, Cautions And Notes.....	0001 00
Equipment Characteristics, Capabilities And Features	0001 00

TABLE OF CONTENTS - Continued

WP Sequence No.

CHAPTER 1 - DESCRIPTION AND THEORY OF OPERATION

Location And Description Of Major Components	0002 00
Equipment Data	0002 00
Common Tools And Equipment.....	0002 00
Theory Of Operation	0003 00

CHAPTER 2 - OPERATOR INSTRUCTIONS

General	0004 00
Controls And Indicators	0004 00
Decals And Instruction Plates.....	0004 00
Siting Requirements	0005 00
Assembly And Preparation For Use	0005 00
SHS Operating Procedures	0005 00
Preparation For Movement.....	0005 00
Preparation For Storage Or Shipment.....	0005 00
Operation Under Unusual Conditions	0006 00
Operator Lubrication and Service Parts Information	0007 00

CHAPTER 3 – OPERATOR TROUBLESHOOTING PROCEDURES

Operator Malfunction Symptom Index	0008 00
Operator Troubleshooting Procedures	0009 00

CHAPTER 4 – OPERATOR MAINTENANCE INSTRUCTIONS

Operator Preventive Maintenance Checks And Services (PMCS)	0010 00
Operator Maintenance.....	0011 00
Service Upon Receipt	0012 00
Space Heater Small (Service)	0013 00
Stack Assembly	0014 00
Canister Lid Assembly	0015 00
Burner Shell and Downtube Assembly	0016 00
Tent Collar Assembly.....	0017 00
Preparation For Shipment Or Storage	0018 00

CHAPTER 5 – UNIT MAINTENANCE INSTRUCTIONS

Unit Troubleshooting Procedures	0019 00
Space Heater Small (Repair)	0020 00
Rain Cap Assembly	0021 00
Overflow Hose	0022 00
Fuel Tank QD Connector.....	0023 00
Regulating Float Valve Assembly	0024 00
Fuel Strainer	0025 00
Fuel Shut-off Valve Assembly.....	0026 00
Heat Shield Assembly.....	0027 00

TABLE OF CONTENTS - Continued

WP Sequence No.

CHAPTER 6 - SUPPORTING INFORMATION

References	0028 00
Maintenance Allocation Chart For SHS	0029 00
Introduction To Repair Parts And Special Tools List	0030 00
Repair Parts And Special Tools List – Group 01 Rain Cap Assy	0031 00
Repair Parts And Special Tools List – Group 02 Stack Assy.	0032 00
Repair Parts And Special Tools List – Group 03 Canister Lid Assy	0033 00
Repair Parts And Special Tools List – Group 04 Burner Downtube Assy	0034 00
Repair Parts And Special Tools List – Group 05 Fuel Shut-off Valve Assy.....	0035 00
Repair Parts And Special Tools List – Group 06 Overflow Hose.....	0036 00
Repair Parts And Special Tools List – Group 07 Regulating Float Valve	0037 00
Repair Parts And Special Tools List – Group 08 Fuel Tank QD Connector	0038 00
Repair Parts And Special Tools List – Group 09 Fuel Strainer	0039 00
Repair Parts And Special Tools List – Group 10 Heat Shield Assembly	0040 00
Repair Parts And Special Tools List – Group 11 Tent Collar Assembly	0041 00
Repair Parts And Special Tools List – Group 12 Label Kit	0042 00
Repair Parts And Special Tools List – Group 13 Fuel Cap and Primer Bulb.....	0043 00
Repair Parts And Special Tools List – Group 14 Bulk Material	0044 00
National Stock Number Index	0045 00
Part Number Index.....	0046 00
Components Of End Item (COEI) List & Basic Issue Items (BII) List	0047 00
Additional Authorization List (AAL)	0048 00
Expendable And Durable Items List	0049 00
Mandatory Replacement Parts List.....	0050 00

ALPHABETICAL INDEX	INDEX 1
--------------------------	---------

HOW TO USE THIS MANUAL

This Manual contains General Information, Operating Instructions, Operator Preventive Maintenance Checks and Services (PCMS), Troubleshooting, and Maintenance/Repair instructions for the Space Heater Small (SHS).

Chapter 1 contains introductory information on the SHS and its associated equipment as well as a Theory of Operation. Chapter 2 includes operating instructions under usual and unusual conditions. Chapter 3 contents include operator troubleshooting, PMCS, and service procedures. Chapter 4 contains Unit Maintenance instructions. Chapter 6 contains references and other supporting information. Chapter 6 also includes the Repair Parts and Special Tools List (RPSTL) which identifies those parts or tools which are unique to the operation and maintenance of this equipment.

Manual Organization and Page Numbering System. The Manual is divided into six major chapters that detail the topics mentioned above. Within each chapter are work packages covering a wide range of topics. Each work package is numbered sequentially starting at page 1. The work package has its own page numbering scheme and is independent of the page numbering used by other work packages. Each page of a work package has a page number of the form XXXX YY-ZZ where XXXX is the work package number (e.g. 0010 is work package 10) and YY is the revision number for that work package and ZZ represents the number of the page within that work package. A page number such as 0010 00-1/2 blank means that page 1 contains information but page 2 of that work package has been intentionally left blank.

Finding Information. The Table of Contents permits the reader to find information in the manual quickly. The reader should start here first when looking for a specific topic. The Table of Contents lists the topics contained within each chapter and the Work Package Sequence Number where it can be found.

Example: If the reader were looking for instructions on "Preventive Maintenance Checks and Services", which is a Operator Maintenance topic, the Table of Contents indicates that Operator Maintenance information can be found in Chapter 3. Scanning down the listings for Chapter 3, "Preventive Maintenance Checks and Services" information can be found in WP 0010 00 (i.e. Work Package 10).

An Alphabetical Index can be found at the back of the Manual, and lists specific topics with the corresponding work package.

**SPACE HEATER SMALL (SHS)
GENERAL INFORMATION****SCOPE**

This Technical Manual contains instructions for the operation as well as preventive and corrective maintenance for the Space Heater Small (SHS) (1) and its associated components consisting of a stack assembly (2), rain cap (3) with guy lines (4), fuel overflow hose (5), priming bulb (6) and tent collar assembly (7). The SHS is fielded as a safe and versatile heat source for the Army's field operations.

Type of Manual: Operator's and Unit Maintenance Manual (Including Repair Parts And Special Tools Lists)

NSN Number and Equipment Name: Space Heater Small (SHS), NSN 4520-01-478-9207

Purpose of Equipment: The SHS provides heat in a range up to 12,000 BTU/hour. It is designed to be used in the Soldier Crew Tent and other 4 or 5 men tents in moderate to arctic conditions. The SHS operates with various types of liquid fuel which are listed in WP 0002 00.



**SPACE HEATER SMALL (SHS)
GENERAL INFORMATION**

MAINTENANCE FORMS RECORDS AND REPORTS.

Department of the Army forms and procedures used for equipment maintenance will be those prescribed by DA PAM 738-750, Functional Users Manual for The Army Maintenance Management System (TAMMS) (Maintenance Management Update).

REPORTING EQUIPMENT IMPROVEMENT RECOMMENDATIONS (EIRs).

If your SHS needs improvement, let us know. Send us an EIR. You, the user, are the only one who can tell us what you don't like about your equipment. Let us know why you don't like the design or performance. Put it on an SF368 Product Quality Deficiency Report. Mail it to Commander, U.S. Army Soldier and Biological Chemical Command, ATTN: AMSSB-RIM-E(N), Kansas Street, Natick, MA 01760-5052. We will send you a reply.

SAFETY, CARE, AND HANDLING

General Safety. While in operation, the heater presents a potential burn and carbon monoxide hazard. Proper precautions should be observed while operating the heater.

Observe all warning and caution notes that appear before each maintenance operation. Refer also to the Warning Summary at the beginning of this technical manual.

CORROSION PREVENTION AND CONTROL (CPC).

Corrosion Prevention and Control (CPC) of Army materiel is a continuing concern. It is important that any corrosion problems with this item be reported so that the problem can be corrected and improvements can be made to prevent the problem in future items.

While corrosion is typically associated with rusting of metals, it can also include deterioration of other materials, such as rubber or plastic. Unusual cracking, softening, swelling or breaking of these materials may be a corrosion problem.

If a corrosion problem is identified, it can be reported using SF 368, Product Quality Deficiency Report. Use of key words such as "corrosion", "rust", "deterioration", or "cracking" will ensure that the information is identified as a CPC problem. This form should be submitted to the address specified in DA PAM 738-750.

DESTRUCTION OF ARMY MATERIEL TO PREVENT ENEMY USE.

For procedures to destroy this equipment to prevent its use by the enemy, refer to TM 750-244-3, Procedures for Destruction of Material to Prevent Enemy Use.

NOMENCLATURE CROSS-REFERENCE LIST.

Common Name	Official Name
SHS	Space Heater Small
Burner Rate Control	Regulating Float Valve
ON/OFF Control Valve	Fuel Shut Off Valve
Tent	Soldier Crew Tent

**SPACE HEATER SMALL (SHS)
GENERAL INFORMATION**

LIST OF ABBREVIATIONS/ACRONYMS.			
AAL	Additional Authorization List	lt	Liter
BII	Basic Issue Item	MSDS	Material Safety Data Sheet
BTU	British Thermal Unit	MTOE	Modified Table of Org and Equipment
CO	Carbon Monoxide	NBC	Nuclear, Biological, Chemical
COEI	Component of end item	NSN	National Stock Number
CPC	Corrosion Prevention Control	PMCS	Preventive Maintenance Checks and Services
cm	Centimeter	POL	Petroleum, Oil and Lubricant
°C	Degrees Celsius	QD	Quick Disconnect
°F	Degrees Fahrenheit	RPSTL	Repair Parts and Special Tools List
EIR	Equipment Improvement Recommendation	TMDE	Test, Measurement, Diagnostic Equipment
gal	Gallons	TOE	Table of Organization and Equipment
hr	Hour	U/M	Unit of Measure
IAW	In Accordance With	UOC	Usable On Code
in	Inches	WP	Work Package
Kg	Kilogram		
lbs	Pounds		

SAFETY, CARE AND HANDLING, WARNINGS, CAUTIONS AND NOTES.

Always pay attention to Warnings, Cautions and Notes appearing throughout the manual. They will appear prior to applicable procedures. Ensure you read and understand their content to prevent serious injury to yourself and others, or damage to equipment.

EQUIPMENT CHARACTERISTICS, CAPABILITIES AND FEATURES.

CHARACTERISTICS	CAPABILITIES AND FEATURES
! Multipurpose	Operable with: Liquid Fuels: Diesel, DF-A, DF-1, DF-2, JP8, Jet A1 and Kerosene SHS operates at 9,000 to 12,000 BTU/hour output
! Portable	
! Self-contained	
! Lightweight	
! Also Functions As Food Warmer	
! Combustion by-products vented outside	

THIS PAGE INTENTIONALLY LEFT BLANK

TM 10-4520-263-12&P

CHAPTER 1

**DESCRIPTION AND
THEORY OF OPERATION**

SPACE HEATER SMALL (SHS)

THIS PAGE INTENTIONALLY LEFT BLANK

**SPACE HEATER SMALL (SHS)
GENERAL INFORMATION**

LOCATION AND DESCRIPTION OF MAJOR COMPONENTS

Rain cap assembly (1). The rain cap assembly (1) is installed on the top of the nested stack assembly (2) to prevent down-drafts from entering the heater during operation. It also prevents rain, leaves, and other debris from entering the stack. Guy lines (3), secured to three wire ropes (4), are secured to loops at the corner of the tent and act to stabilize the entire stack assembly (2) in an upright (vertical) position during heater operation.

Stack assembly (2). Consists of six pipe sections (middle sections not shown) of decreasing diameter. When assembled, the sections form a slightly cone-shaped stack with the largest diameter section at the base and the smallest diameter at the top. Each section is flanged on its smaller end in order to fit into the next higher section and stamped with a number for easy identification. The stack assembly (2) seats in the stack adapter (5), allowing combustion gases to discharge outside the tent during operation. When disassembled, the sections fit inside each other and on either side of the burner for storage.

Fuel Tank (6). The fuel tank (6) stores enough fuel for up to six hours of operation. The fuel cap (7) is removed to allow refueling.

Primer Bulb (8). The primer bulb (8) consists of a long slender tube with a rubber squeeze bulb. The primer bulb is used to extract a small amount of fuel that is injected into the burner and used to prime the heater at start-up.

Air Vent/Primer Port (9). The air vent/primer port (9), located on the top of the fuel tank (6), is opened during operation to allow air into the fuel tank (6). The air vent/primer port (9) can also be removed to allow the primer bulb (8) to extend down into the fuel tank (6) to acquire a small amount of fuel for priming.

Lid Assembly (10). The lid assembly (10) fits onto a circular opening on the top of the heater body. The built-in sight glass (11) allows the user to monitor the burner flame and permits access to the burner down tube assembly (12) when igniting liquid fuel. Two pot supports (13) rotate outward to allow a cooking pot to be placed on top of the lid assembly (10) for warming food. The lid assembly is secured to the top of the heater body by two latches (14) located on either side of the heater body.

Burner Shell Assembly (15). The burner shell is the area of the heater where combustion occurs. The burner shell consists of a perforated burner shell (16) and up-tube (17) which is welded into the base of the burner shell (16). It permits fuel vapors to flow into the down-tube assembly (18) during operation.

Down-tube Assembly (18). The capped down tube (18) is positioned over the up-tube (17) and is removable through the lid assembly (10). During operation, fuel flows into the up-tube (17) where its level is gravity-maintained with the regulating float valve (19).

Regulating Float Valve (19). Controls the amount of fuel being delivered to the burner by utilizing gravity feed. As the height of the float regulating valve is changed via the burner rate control (20), the amount of fuel being delivered to the burner will increase or decrease accordingly.

Burner Rate Control (20). The Burner Rate Control (20) regulates the amount of fuel flowing to the burner by moving the regulating float valve (19) up and down.

Fuel Shut-off Valve (21). The fuel shut-off valve (21) controls the flow of fuel from the fuel tank (6) to the regulating float valve (19).

Fuel Quick Disconnect (22). Allows an external fuel source to be connected to the Space Heater Small, bypassing the internal fuel tank and substantially increasing run time.

Overflow Hose (23). The Overflow Hose (23) is attached to a barb fitting located under the regulating float valve (19) and allows any overflow fuel to be conducted out of the tent.

Heat Shield (24). A perforated heat shield (24) surrounds the Space Heater Small and prevents accidental contact with the hot burner assembly parts during heater operation.

Fuel strainer (25). The fuel strainer (25) is located between the fuel tank and the regulating float valve and acts to filter any dirt or other foreign matter that may be in the fuel supply.

Tent Collar Assembly (26). The tent collar assembly (26) is installed on the inner roof opening (27) of the tent and effectively reduces the diameter of the roof opening (27), thereby providing a weathertight pass-through for the stack assembly (2).

Stack Lock (28). The stack lock (28) is a sliding bracket located on the top of the fuel tank (6). The stack lock (28) slides over the fuel cap (7) when the stack assembly (2) is in position, preventing refueling of the heater inside the tent.

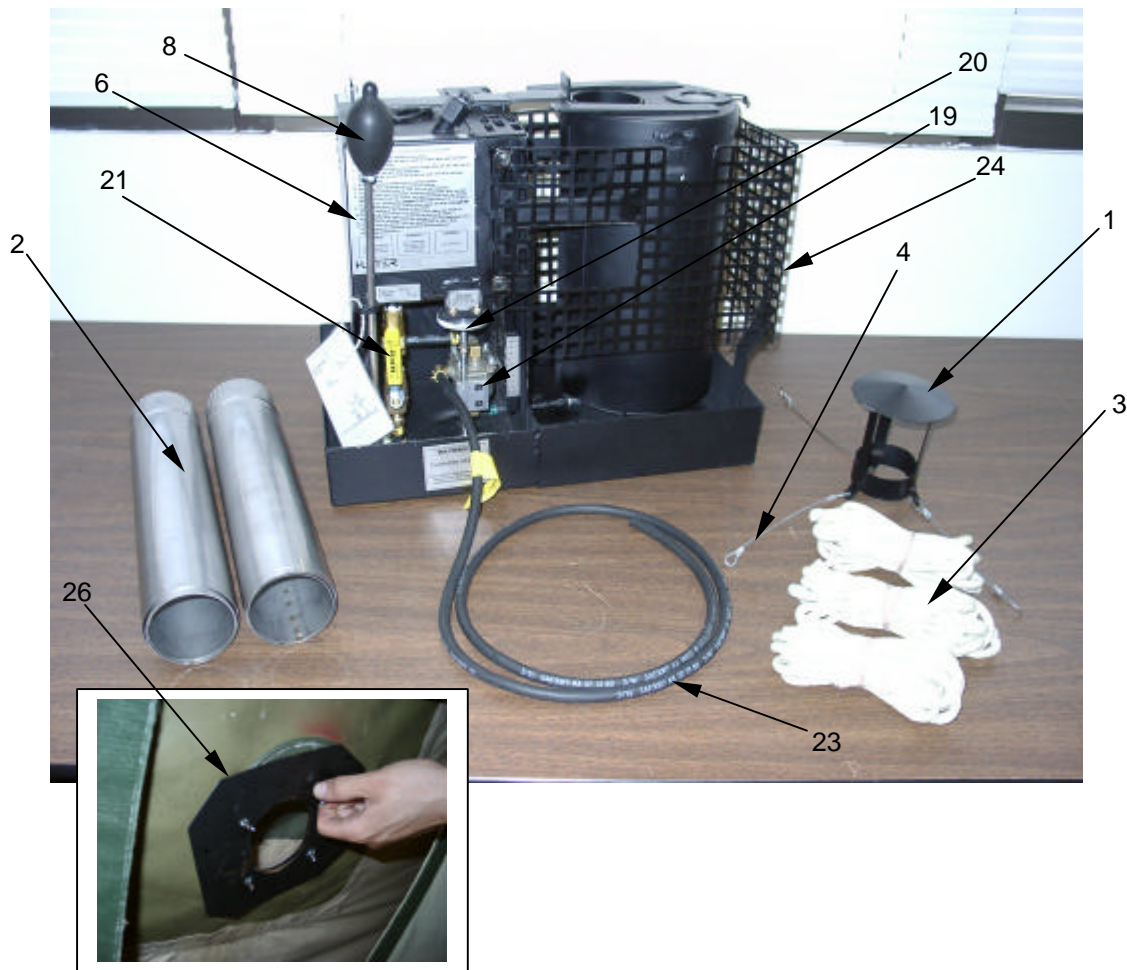

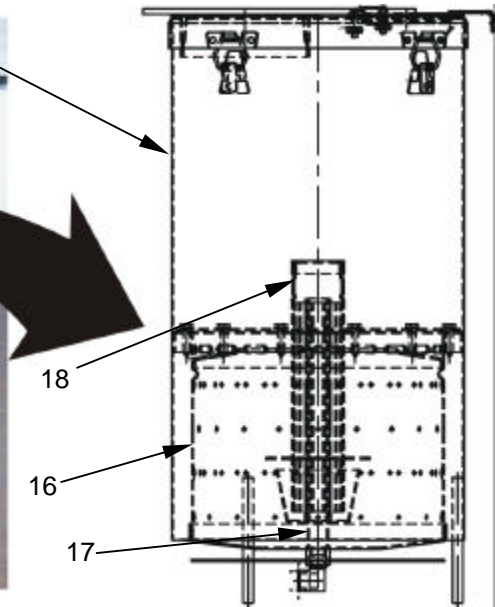
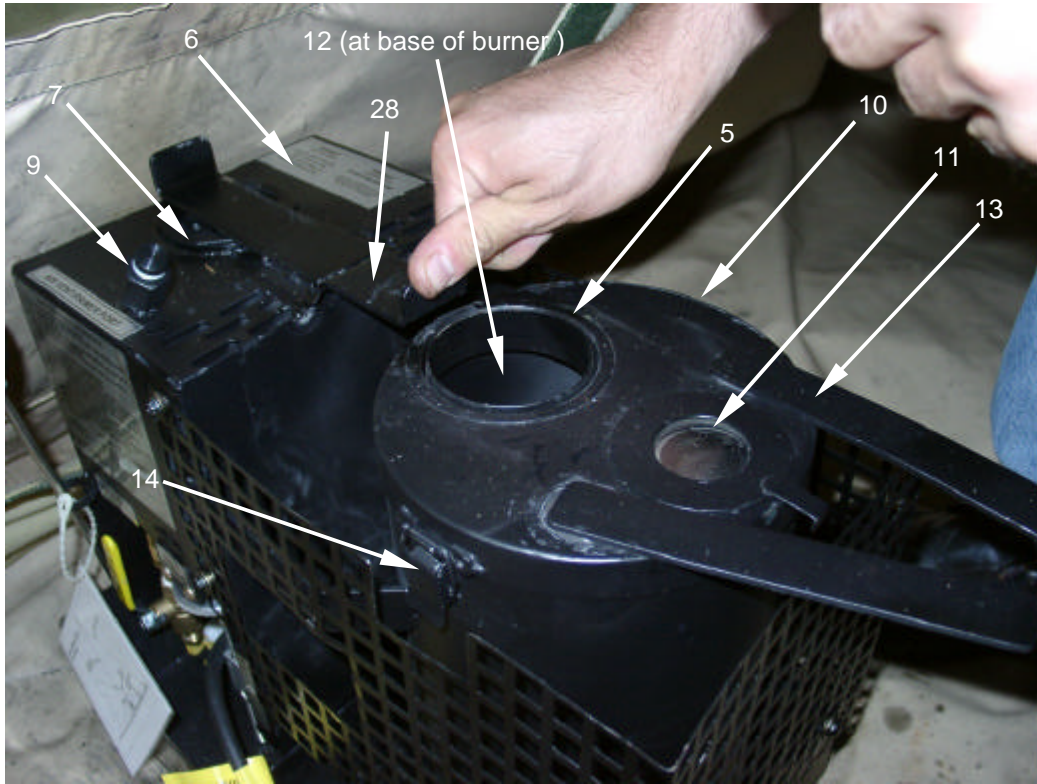

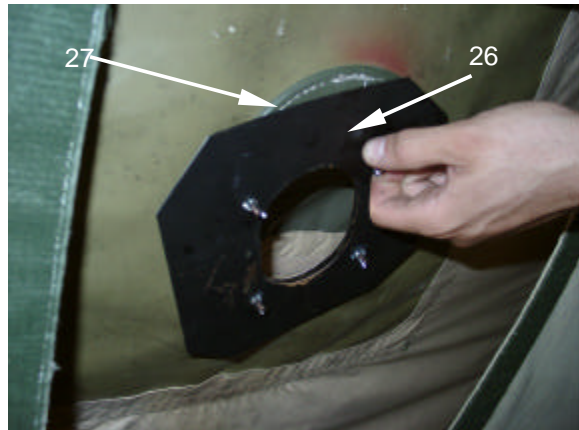
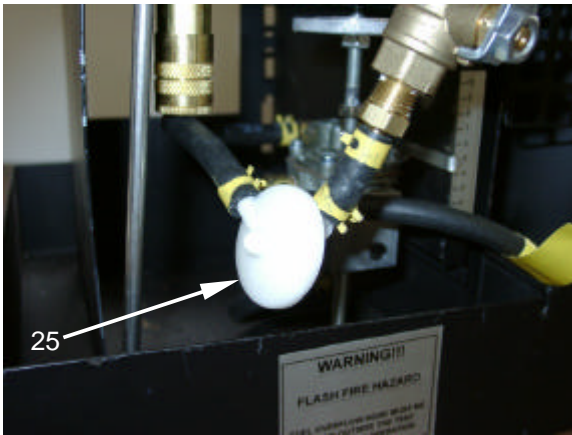
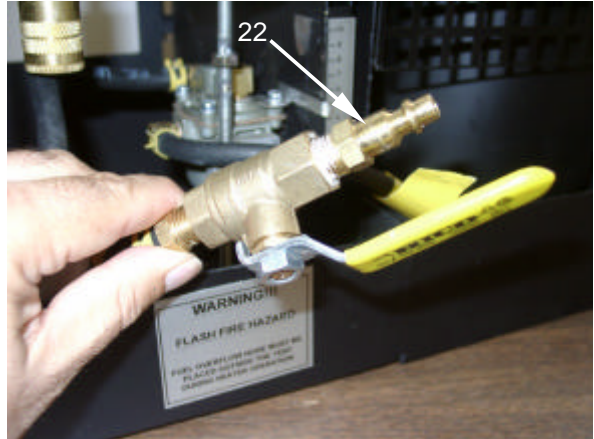
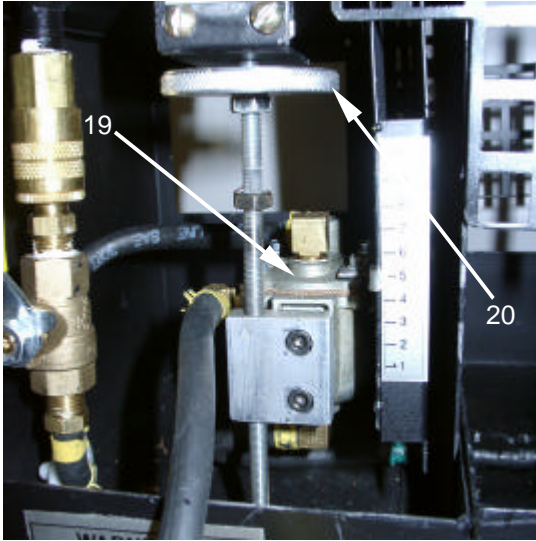

EQUIPMENT DATA

The following technical and identification data pertains to the SHS and selected support equipment.

Equipment Specification Data

Table 1. Equipment Data

WEIGHT:	
SHS	32 lbs (14.5 Kg)
DIMENSIONS:	
Height	17 in (43.2 cm)
Width	9 in (22.9 cm)
Depth	17.5 in (44.4 cm)

Performance Specification Data.



WARNING!
Fire or Explosion

Do not use gasoline, used motor oil, cleaning solvents, or any other fuel not authorized for use in the SHS. Use of an unauthorized fuel may result in fire or explosion.

FUEL TYPES USABLE FOR HEATER OPERATION:
JP-8, Diesel (DF-A, DF-1, DF-2)

LIQUID FUEL CONSUMPTION:
Rate of fuel consumption at maximum firing rate:
 Diesel, DF-1, DF-2 0.42 fluid ounces/minute (0.197 gal.hr)
 JP-8, DF-A, Jet A1, Kerosene 0.4396 fluid ounces/minute (0.206 gal.hr)

OUTPUTS:
Heater Burn Rate (setting dependent) 9,000 to 12,000 BTU/hr

ENVIRONMENTAL:
 Operating temperatures -60°F to +50°F (-51°C to +10°C)
 Operating elevations to 6,000 ft above sea level

COMMON TOOLS AND EQUIPMENT

For authorized common tools and equipment, refer to the Modified Table of Organization and Equipment (MTOE), CTA 50-970, Expendable/Durable Items (Except: Medical, Class V, Repair Parts, and Heraldic Items), or CTA 8-100, Army Medical Department Expendable/Durable Items, as applicable to your unit.

Repair parts are listed and illustrated in the repair parts and special tools list located in work packages 0031 through 0043.

SPACE HEATER SMALL (SHS)
THEORY OF OPERATION

The Space Heater Small (SHS) operates independently of outside equipment on a regularly maintained supply of liquid fuel. Combustion gases are exhausted out the roof of the shelter through the stack assembly.

The heater has variable heat output, and can be controlled by the operator. During operation, heat output is controlled with the burner rate control.

During normal operation, and with proper burn rate control, the heater will produce an even, yellow-colored flame. The SHS will not emit smoke or other combustion gases into the space being heated. Proper safety precautions should be maintained in the area surrounding the heater as the entire unit will be hot during operation.

The SHS requires minimal maintenance; refer to the Preventive Maintenance Checks and Services as detailed in work package 0010 for more information.

An operational cycle for the Space Heater Small **(1)** begins when the air vent/primer port cap **(2)** is temporarily removed and the primer bulb **(3)** used to extract a small amount of fuel from the fuel tank **(4)**. This priming fuel is then injected into the burner shell **(5)** through the sight glass opening **(6)** on the lid assembly **(7)**.

The fuel shut-off valve **(8)** is placed in the ON position and the air vent **(9)** located on the air vent/primer port cap **(2)** is opened two or three turns.

Liquid fuel flows from the fuel tank **(4)** through the fuel quick disconnect **(10)** and fuel strainer **(11)** to the regulating float valve **(12)**. The regulating float valve **(12)** controls the amount of fuel that flows to the burner **(5)** via a gravity feed concept. As the height of the regulating float valve **(12)** is raised or lowered using the burner rate control **(13)**, the amount of fuel delivered to the burner is increased or decreased respectively. Fuel then flows into the burner up-tube **(14)** inside the burner shell **(5)**.

A burning piece of fuel-dampened tissue is dropped to the bottom of the burner shell **(5)** through the sight glass opening **(6)** on the lid assembly **(7)**. The burning tissue then ignites the priming fuel. After five to ten minutes, enough heat is produced by the burning priming fuel to vaporize fuel within the up-tube **(14)**.

Fuel vapors are generated and discharged into the downtube **(15)**, where it enters the burner shell **(5)**, mixes with air, beginning the combustion process. By the time all the priming fuel is consumed, the combustion process has been established and will continue as long as there is fuel in the fuel tank **(4)** or the fuel shut-off valve **(8)** remains in the ON position.

Air, required for combustion, is drawn through the bottom of the heater and into the burner shell **(5)**. The lid assembly **(7)** is secured to the heater body by latches **(16)**. This prevents air leakage which would impair operating efficiency while the heater is in use.

The flame can be monitored through the sight glass **(17)** on the lid assembly **(7)**. Combustion gases pass from the burner shell **(5)** through the heater body and up through the stack assembly **(18)**, and outside the shelter through the rain cap **(19)**.

Once combustion is established, heat output inside the tent is controlled by rotating the burner rate control **(13)** up or down. An indicator scale **(20)** labeled from 1 to 10 indicates the current position of the regulating float valve **(12)**.

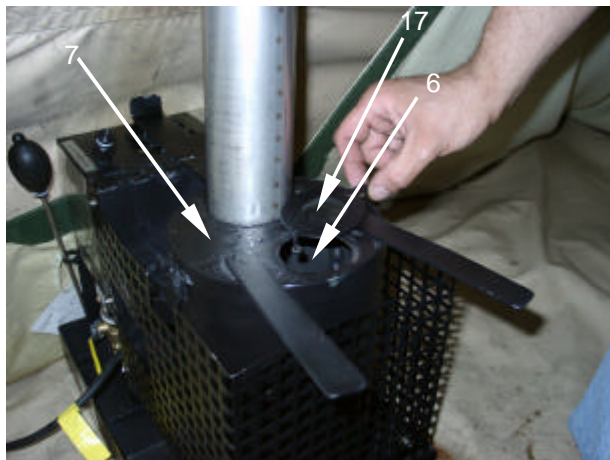
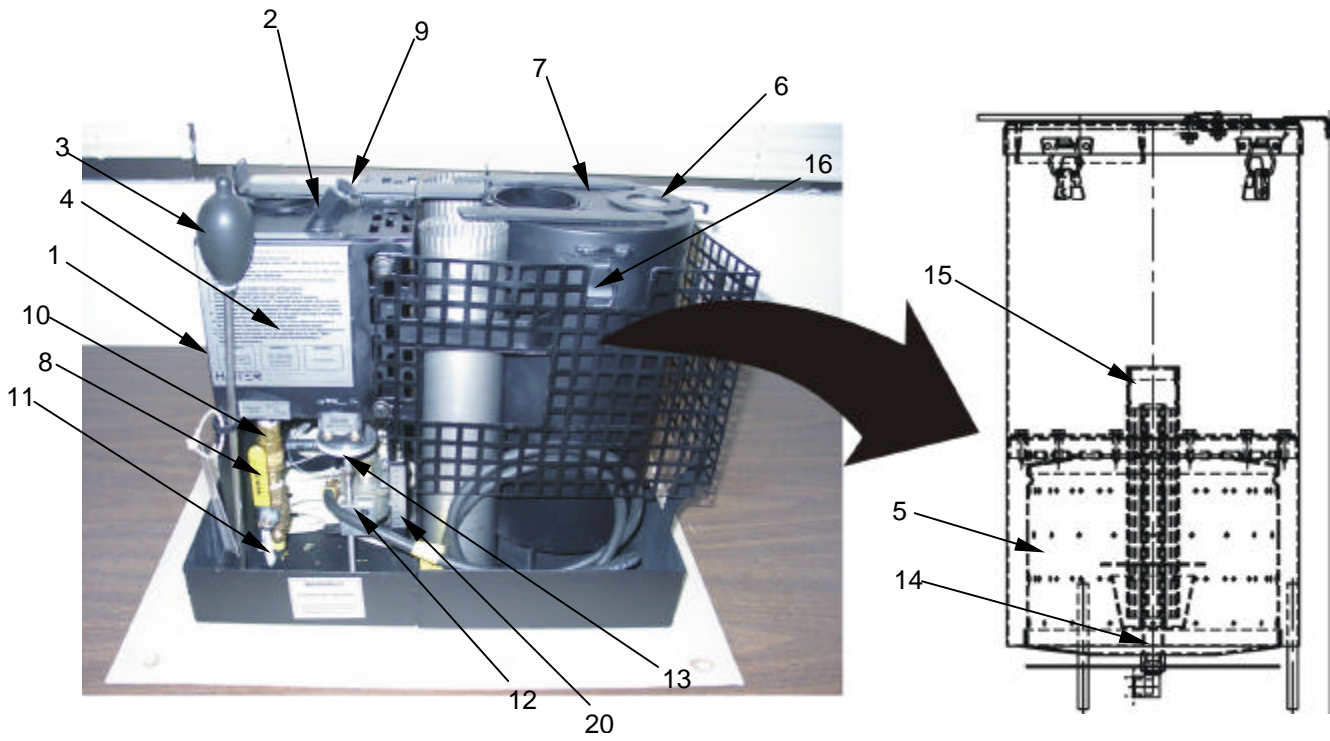

TM 10-4520-263-12&P

CHAPTER 2
OPERATOR INSTRUCTIONS
SPACE HEATER SMALL (SHS)

THIS PAGE INTENTIONALLY LEFT BLANK

**SPACE HEATER SMALL (SHS)
CONTROLS, INDICATORS, AND LABELS/INSTRUCTION PLATES**

GENERAL

The following illustrations and tables show the location and function of each control and indicator on the SHS and its associated equipment. Table 1 describes the controls and indicators for the SHS.

Table 1. SHS Controls and Indicators

KEY	ITEM	FUNCTION
1	AIR VENT/PRIMER PORT CAP	Allows air to enter the fuel tank during operation so that fuel is able to flow freely through the fuel management system. The primer port cap is removable so that fuel can be extracted from the fuel tank for priming.
2	BURNER RATE CONTROL	Controls fuel flow by moving zero pressure regulator to desired setting.
3	BURN RATE INDICATOR SCALE	A scale from 1 to 10 that indicates the relative burn rate of the heater. One is the lowest setting and ten is the highest.
4	FUEL ON/OFF CONTROL	A ball valve that has an ON-OFF position. Controls fuel flow from fuel tank to the regulating float valve.
5	LID ASSEMBLY SIGHT GLASS	Located on the top of the lid assembly, the sight glass allows viewing of flame in burner.
6	FUEL CAP	Located on the top of the fuel tank, can be removed to gain access to fuel tank for refueling.
7	LID ASSEMBLY LATCHES	Two latches located on either side of the lid assembly that secure the lid assembly to the burner canister.
8	PRIMER BULB	Slender aluminum tube with rubber squeeze bulb that permits fuel to be extracted from the fuel supply and injected into the burner shell for priming.
9	FUEL QUICK DISCONNECT	Fuel quick disconnect fitting that allows an external fuel supply to be connected to the heater.



LABELS AND INSTRUCTION PLATES

The following labels and instruction plates are found on the SHS components as indicated.

Item	Label	Description
1	<div style="border: 1px solid black; padding: 5px; text-align: center;"> <p>AIR VENT/PRIMER PORT</p> </div>	Air Vent/Primer Port Label
2	<div style="border: 1px solid black; padding: 5px;"> <p style="text-align: center;"><u>OPERATING INSTRUCTIONS-SHS HEATER</u></p> <ol style="list-style-type: none"> 1. See heater manual for detailed instructions. 2. Never attempt to light the burner while it is HOT. Wait until the heater has completely cooled. 3. Use only authorized fuels in the heater: Diesel, DFA, D1, D2, JF8, Jet A1 and Kerosene. DO NOT USE GASOLINE. 4. Always open the air vent on top of the fuel tank even if an auxiliary source is used. 5. Assemble stack on heater prior to starting heater. 6. Adjust the fuel regulating valve to the #5 setting. 7. Turn the fuel shutoff valve to "ON" and wait for 2 minutes. 8. Open the glass lid of the heater. Using the primer bulb, draw one full squeeze of fuel from your source and squirt it evenly onto the bottom of the burner. (Double the amount if the temperature is 0° F or less.) 9. Light a small piece of fuel soaked tissue paper and drop it through the glass lid opening to the bottom of the burner. 10. Close the lid and wait for 5-10 minutes. Then adjust the height of the regulating float valve to obtain the desired heat output. 11. If the burner is smoking, lower the setting on the fuel regulating valve. 12. To shut down the burner, turn the shutoff valve to "OFF". Wait for the heater to completely cool before disassembling or performing maintenance. <div style="display: flex; justify-content: space-around; margin-top: 10px;"> <div style="border: 1px solid black; padding: 2px; font-size: 8px;"> <p style="text-align: center; margin: 0;">WARNING!!!</p> <p style="text-align: center; margin: 0;">FLASH FIRE HAZARD NEVER ATTEMPT TO LIGHT A HOT BURNER</p> </div> <div style="border: 1px solid black; padding: 2px; font-size: 8px;"> <p style="text-align: center; margin: 0;">WARNING!!!</p> <p style="text-align: center; margin: 0;">KEEP HANDS AND FACE AWAY FROM LID OPENING TO PREVENT BURNS</p> </div> <div style="border: 1px solid black; padding: 2px; font-size: 8px;"> <p style="text-align: center; margin: 0;">WARNING!!!</p> <p style="text-align: center; margin: 0;">HOT SURFACES</p> </div> </div> <div style="margin-top: 10px; font-size: 10px;"> <p>HUNTER <small>Hunter Manufacturing Company 30525 Aurora Road Solon, OH 44139 www.hunterheater.com</small></p> <p style="text-align: right; margin-right: 50px;">SERIAL NUMBER _____</p> </div> </div>	Instruction Label
3	<div style="border: 1px solid black; padding: 5px; text-align: center;"> <p>SHUTOFF VALVE ON OFF</p> </div>	Fuel Shut-off Valve Label
4	<div style="border: 1px solid black; padding: 5px; text-align: center;"> <p>REGULATING FLOAT VALVE</p> <p>HIGH LO</p> </div>	Regulating Float Valve Label
5	<div style="border: 1px solid black; padding: 5px; text-align: center;"> <p>—10</p> <p>—9</p> <p>—8</p> <p>—7</p> <p>—6</p> <p>—5</p> <p>—4</p> <p>—3</p> <p>—2</p> <p>—1</p> </div>	Burner Rate Indicator Scale Label

Item	Label	Description
6	<div style="border: 1px solid black; padding: 5px; text-align: center;"> <p><u>WARNING!!!</u></p> <p><u>FLASH FIRE HAZARD</u></p> <p>FUEL OVERFLOW HOSE MUST BE PLACED OUTSIDE THE TENT DURING HEATER OPERATION</p> </div>	Overflow Warning Label
7	<div style="border: 1px solid black; padding: 5px;"> <div style="display: flex; justify-content: space-around;"> <div style="border: 1px solid black; padding: 5px; text-align: center; width: 45%;"> <p><u>WARNING!!!</u></p> <p><u>FLASH FIRE HAZARD</u></p> <p>ALWAYS KEEP THE AIR VENT OPEN ON THE FILLER CAP DURING ALL HEATING OPERATIONS</p> </div> <div style="border: 1px solid black; padding: 5px; text-align: center; width: 45%;"> <p><u>WARNING!!!</u></p> <p><u>FLASH FIRE HAZARD</u></p> <p>DO NOT USE GASOLINE</p> <p>USE ONLY AUTHORIZED FUELS IN THIS HEATER; DIESEL, DFA,D1,D2, JP8, JET A1, KEROSENE</p> </div> </div> </div>	Air Vent/Authorized Fuel Warning Label
8	<div style="border: 1px solid black; padding: 5px;"> <div style="display: flex; justify-content: space-around;"> <div style="border: 1px solid black; padding: 5px; text-align: center; width: 45%;"> <p><u>WARNING!!!</u></p> <p><u>FLASH FIRE HAZARD</u></p> <p>FUEL TANK MUST BE DRAINED PRIOR TO STORAGE OR TRANSPORT</p> </div> <div style="border: 1px solid black; padding: 5px; text-align: center; width: 45%;"> <p><u>WARNING!!!</u></p> <p><u>FLASH FIRE HAZARD</u></p> <p>TURN HEATER OFF AND ALLOW TO COOL PRIOR TO RE-FUELING</p> </div> </div> </div>	Fuel Tank/Heater Off Warning Label

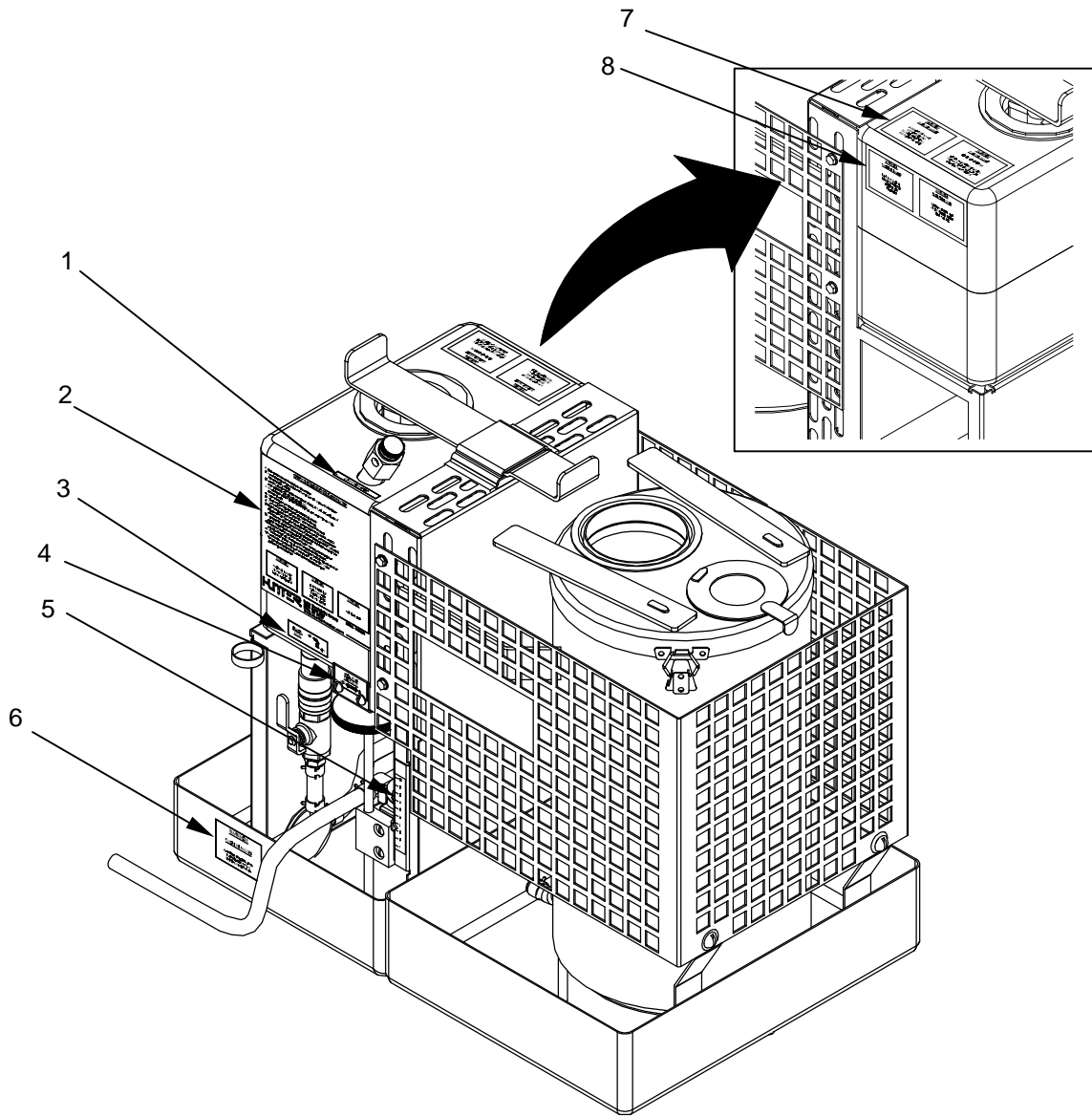

**SPACE HEATER SMALL (SHS)
OPERATION UNDER USUAL CONDITIONS**

PREPARING THE SHS FOR OPERATION**SITING REQUIREMENTS**

The siting requirements for the Space Heater Small (SHS) are dictated by the siting requirements for the Soldier Crew Tent (SCT) or Five Soldier Crew Tent (FSCT) since the heater is installed inside the shelter. The tent should be installed in accordance with TM 10-8340-226-13&P entitled "Operator's and Unit Maintenance Manual including Repair Parts and Special Tools List for the Five Soldier Crew Tent (FSCT)" or TM 10-8340-227-13&P entitled "Operator's and Unit Maintenance Manual including Repair Parts and Special Tools List for the Soldier Crew Tent (SCT)".

BEFORE OPERATION PMCS

Perform the "Before Operation PMCS" on all SHS system components as outlined in WP 0010, prior to preparing the heater for use. All scheduled maintenance must be performed on the heater and its associated equipment prior to use.

UNPACKING THE SHS SYSTEM COMPONENTS**CAUTION!****Do Not Leave Any Components Inside Heater**

All components stored in the heater must be removed prior to operation.

The Space Heater Small utilizes the area inside its shell for the storage of components during movement and storage. Before the SHS can be used, all components must be removed from the storage area.

To unpack the SHS components, remove the rain cap assembly **(1)** with guy lines **(2)** as well as the stack assembly **(3)** and tent collar assembly **(4)** from their stowage locations on either side of the burner canister **(5)**. Place the rain cap **(1)**, guy lines **(2)**, stack assembly **(3)**, and tent collar assembly **(4)** outside the shelter in the vicinity of the tent roof flap for later assembly.

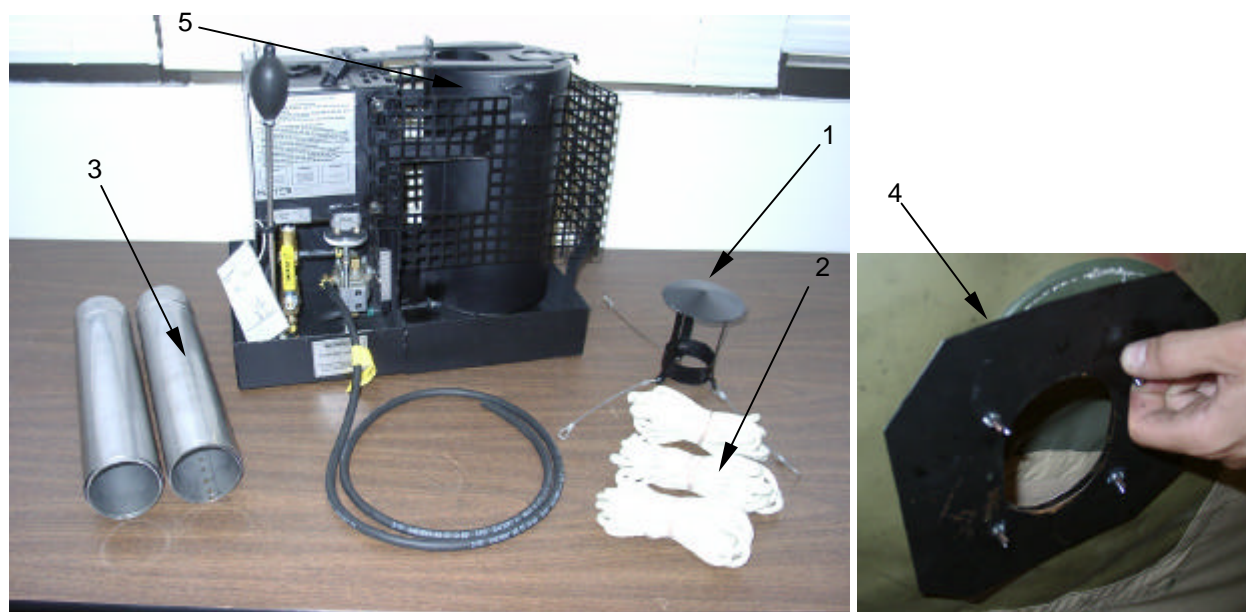

WARNING!
Fire or Explosion

Do not use unauthorized fuels! Use of unauthorized fuel may result in fire/explosion!

Shelter exhaust opening closure flap must be rolled and tied securely. Shelter may catch fire if hot stack assembly contacts the flap.

Poorly fitted stack sections may allow hot stack to fall on shelter and start a fire, or deadly carbon monoxide to leak into shelter. Ensure sections seat together fully.

If an optional external fuel supply is used, set up fuel supply on a clear site seven feet (approx. 2.5 meters) from shelter and away from flame sources. Heat or sparks from stack assembly could ignite fuel supply.

For safe operation, be sure to allow at least one (1) foot (30 cm) of space between the base of the heater and the bottom edge of the shelter wall. Never relight an extinguished flame while the heater is hot. Be sure to allow the heater to cool completely before attempting to relight. Do not attempt to replenish the fuel supply while the heater is in operation. Be certain that there is no open flame in the vicinity of liquid fuel.

**WARNING!****Do Not Use Unauthorized Fuels**

Gasoline, JP-4, Used Motor Oil, Solvents or other unauthorized fuels should **NOT** be used with the SHS under any circumstance. **Only approved liquid fuels may be used.** Using unauthorized fuels in the SHS will create a fire danger and potential for explosion.

**WARNING!****Hot Surfaces**

Do not attempt to handle or perform services on a heater that has recently been in operation. Let the heater cool down before performing these procedures to avoid the possibility of serious burns.

**WARNING!****Carbon Monoxide**

During operation, the SHS produces harmful carbon monoxide (CO) and other gases. Carbon monoxide is a colorless, odorless, and tasteless gas. Mild cases of carbon monoxide poisoning can cause symptoms such as nausea, dizziness or headaches. Severe cases of carbon monoxide poisoning can result in brain damage, heart damage or death. Remember that although CO has no telltale odor, it may mix with other odors which mask its presence; therefore, CO can be present within a mix of seemingly harmless odors.

To prevent CO poisoning, ensure that the SHS exhaust stack sections fit together snugly and that the exhaust gases are properly vented through the roof of the shelter.

The best way to prevent CO poisoning is to keep the SHS in good working order. Ensure that all possible sources of CO leakage have been repaired and that the operating space is well ventilated.

**WARNING!****Cut Hazard**

Some metal components of SHS may have sharp edges. Be careful when handling and assembling the SHS to prevent cuts.

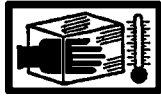

WARNING!
Freeze Hazard

Severe injury may occur to personnel handling metal parts without protective gloves when temperatures are below freezing. Surface of skin may freeze upon contact and tear from the flesh.

Do not allow fuel to come in contact with bare skin. Even though fuel does not freeze, it is extremely cold and will burn exposed skin on contact. Wear protective gloves whenever handling or working with liquid fuel.

OPENING AND SECURING SHELTER ROOF FLAP



WARNING!
Fire or Explosion

Shelter roof flap must be rolled and tied securely. Shelter may catch fire if hot stack assembly contacts the flap.

Open the roof flap **(1)** on the rain fly **(2)** of the tent by separating the hook and pile fastener on the top edge **(3)** of the flap. With the top flap out of the way, separate the hook and pile fastener that surrounds the outer perimeter **(4)** of the roof flap.

Roll the flap **(1)** to the left, taking care to roll the fabric under so that it will not collect any rain water.

Secure the flap with the two flap ties **(5 and 6)** located along the left edge of the flap opening.

Temporarily disengage the three hooks **(7)** that secure the rain fly **(2)** to the tent stake straps **(8)** and fold the rain fly **(2)** back in order to gain access to the roof flap **(9)** located on the outer wall **(10)** of the tent.

Open and secure the second roof flap **(9)** as described above.

Lower the rain fly **(2)** and secure the hooks **(7)** to the tent stake straps **(8)**.

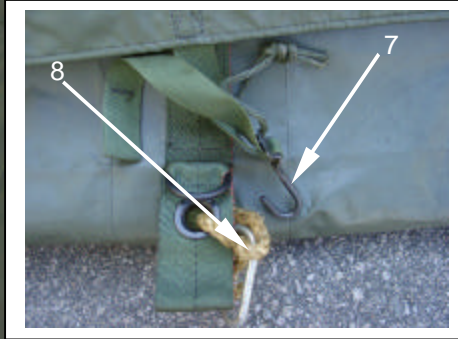

INSTALLATION OF TENT COLLAR ASSEMBLY

The tent collar assembly (1) is provided to reduce the diameter of the shelter roof opening (2) so that the stack assembly is held securely and the amount of open area around the stack where rain might enter is held to a minimum.

The tent collar assembly (1) is supplied in two halves and secured by threaded studs (3) and wingnuts (4). To install the tent collar (1), remove all four wingnuts (4) and set aside. Separate the two halves of the tent collar.

Lift the bottom of the rain fly (5) and slide the portion of the tent collar with the exposed threaded studs (6) under the rain fly (5) and into the shelter roof opening (2). Orient the tent collar so that the studs enter and face the inside of the shelter. Allow the collar to rest in the opening.

Enter the inside of the tent and open the shelter liner flap (7) by separating the hook and pile fasteners around the perimeter of the flap. Roll the liner flap up and secure with the two hook and pile fastener tabs (8) at the top of the flap. Ensure that the liner flap is stowed securely so that it does not come in contact with the stack assembly during heater operation.

Take the portion of the tent collar assembly with the holes (9) and align the threaded studs (3) on the half installed earlier with the holes (9) on the second half.

Press the two halves of the tent collar assembly together and secure with the four wingnuts (4) removed earlier.

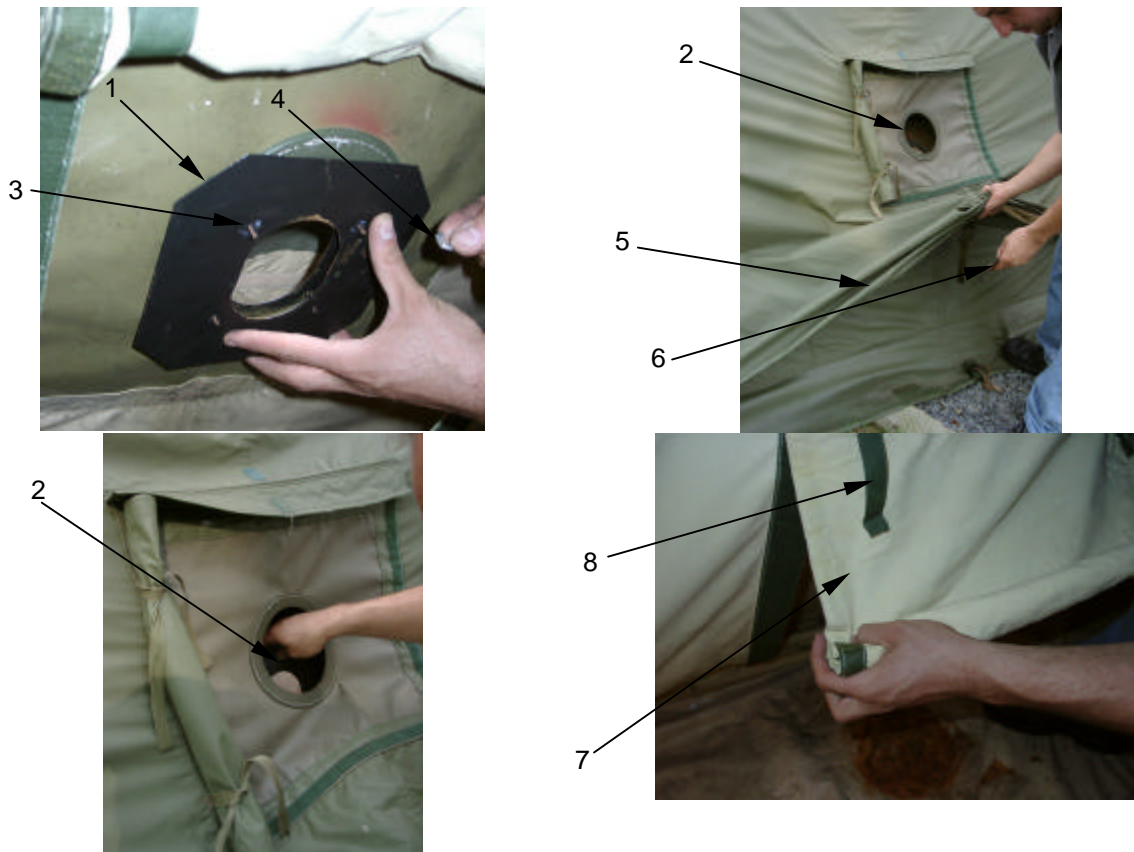

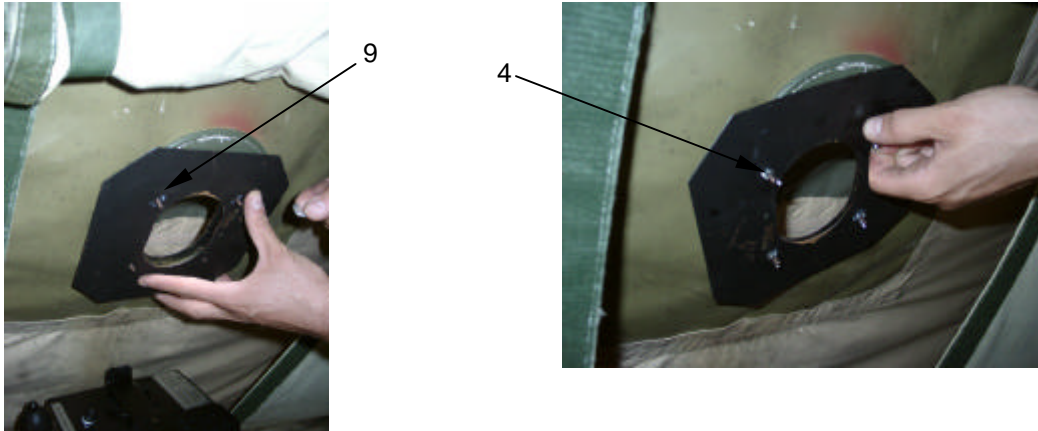

FUELING THE SHS

Before fueling the SHS, select a fueling site at least 50 feet away from the shelter and any flame sources.

Place a section of petroleum absorbent material on the ground to absorb any fuel that may spill during the fueling process. Have a wiping rag ready to wipe up any fuel that may spill. Position the SHS on the petroleum absorbent mat.

Position a fuel can with an authorized fuel as detailed in WP 0002 00 on the petroleum absorbent mat along side the SHS.

To fuel the SHS, slide the stack lock **(1)** over the stack adapter **(2)** to allow access to the fuel tank cap **(3)**. Loosen and remove the fuel tank cap **(3)** and set aside.

Remove the cap from the fuel can and outfit the can with a pouring spout.

Fill the SHS with the approved fuel just below the neck of the fuel tank opening.

Install the fuel tank cap **(3)** and tighten securely.

Move the stack lock **(1)** back into position over the fuel tank cap, permitting access to the stack adapter **(2)** on the top of the heater.

Remove the pouring spout from the fuel can and install the fuel can cap. Tighten securely.

Wipe up any spilled fuel with a wiping rag. Dispose of soiled rags and/or petroleum absorbent mat in accordance with local environmental regulations.

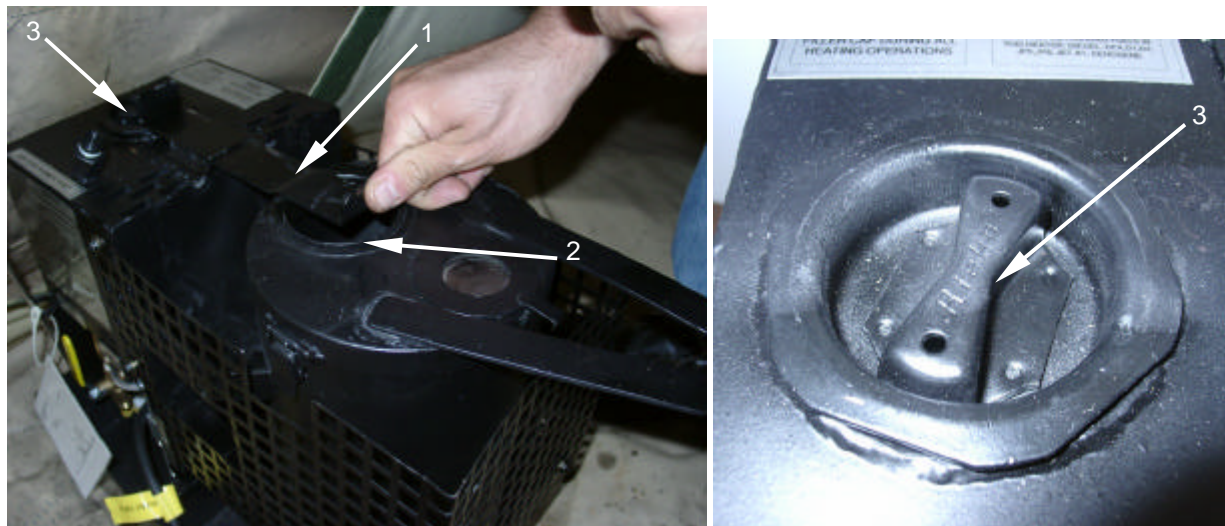

POSITIONING THE SHS INSIDE THE SHELTER

Move the fully fueled heater inside the shelter and position it under the shelter roof opening (1) by placing the end of the heater with the fuel tank (2) toward the shelter wall (3) taking care to align the stack adapter opening (4) on the lid assembly directly beneath the tent collar (5) installed earlier. The opening in the tent collar (5) must align closely with the stack adapter opening (4). When properly positioned, the base of the heater will be approximately 1 foot (30 cm) from the bottom edge of the tent wall.

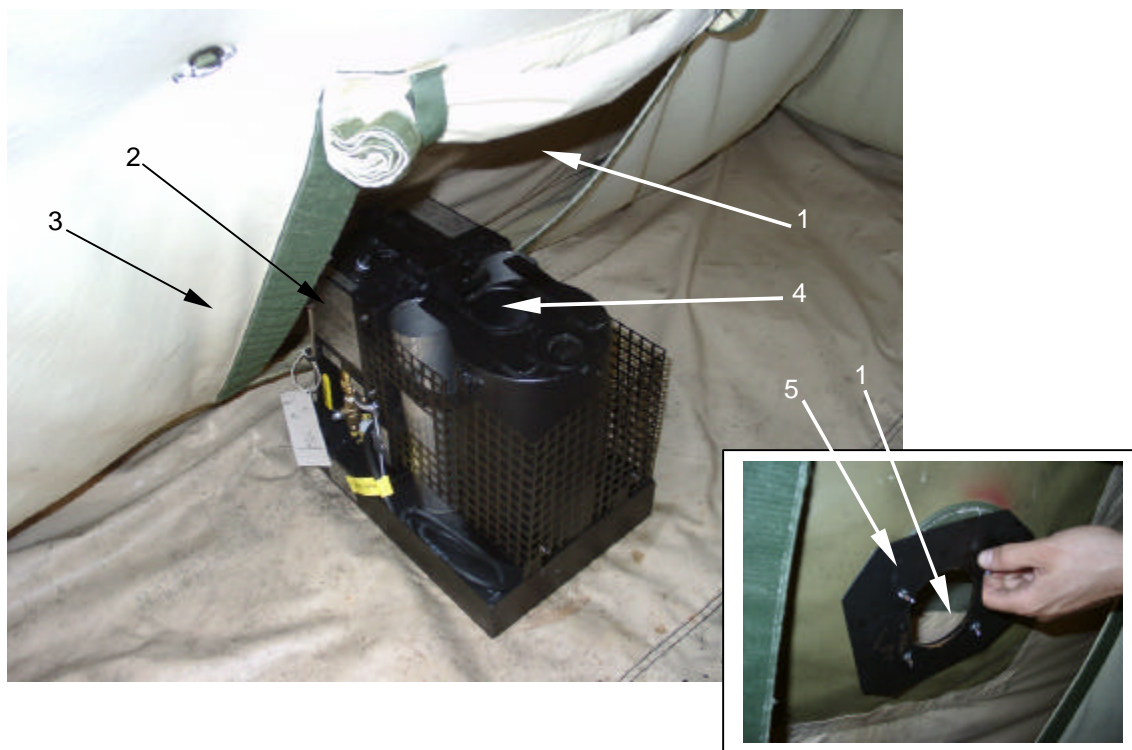

Deploying the Overflow Hose. Uncoil the overflow hose (1) from its stowage area in the heater shell (2). Route the end of the hose through the small opening (3) at the base of the shelter wall to the left of the shelter liner opening.

Exit the shelter and pull the overflow hose (1) out through the opening (4) in the shelter wall. Lay the hose out straight and slightly downhill from the shelter. Place the end of the hose on a section of petroleum absorbent mat (5).

Ensure that the hose is not placed so that it goes uphill. This would cause any overflow fuel to run back toward the shelter.

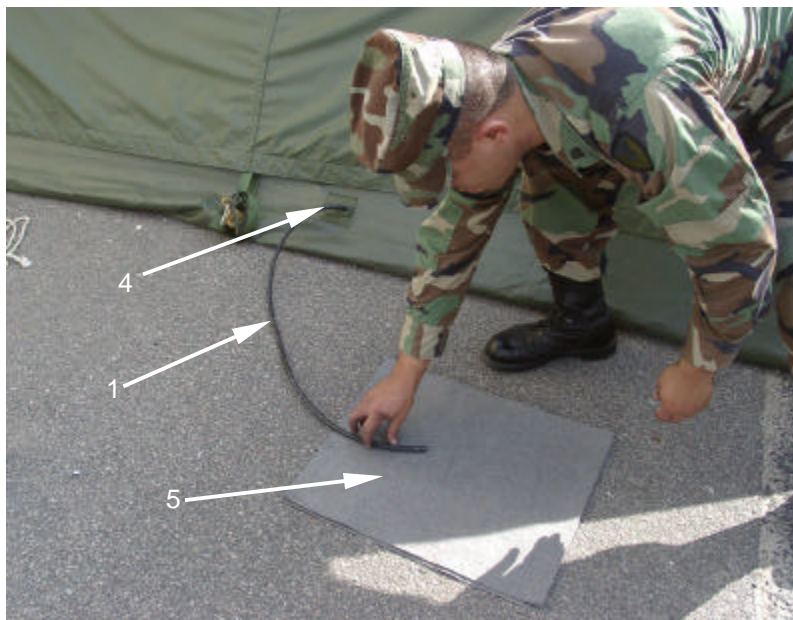
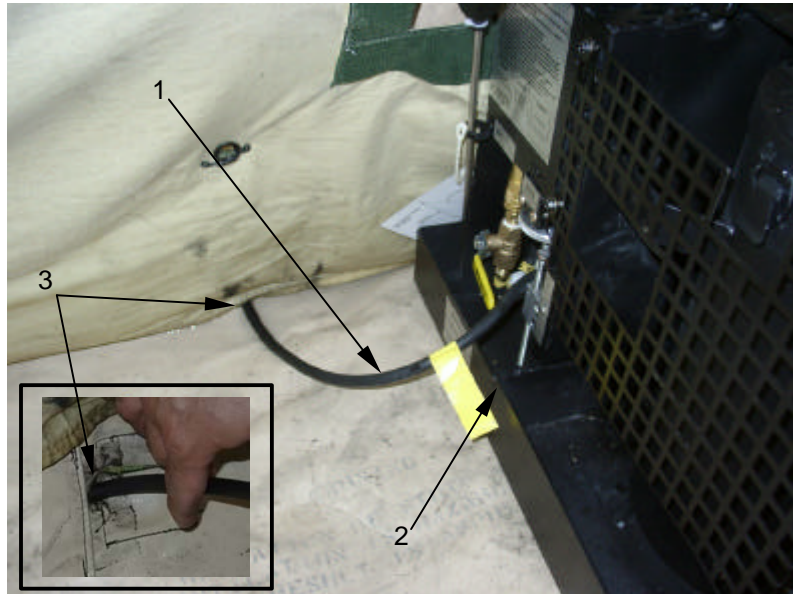

ASSEMBLING THE STACK ASSEMBLY**WARNING!
Fire Danger**

Poorly fitted stack sections may allow hot stack to fall on shelter and start a fire, or deadly carbon monoxide to leak into shelter. Ensure sections seat together securely.

**WARNING!
Carbon Monoxide**

During operation, the SHS produces harmful carbon monoxide (CO) and other gases. Carbon monoxide is a colorless, odorless, and tasteless gas. Mild cases of carbon monoxide poisoning can cause symptoms such as nausea, dizziness or headaches. Severe cases of carbon monoxide poisoning can result in brain damage, heart damage or death. Remember that although CO has no telltale odor, it may mix with other odors which mask its presence; therefore, CO can be present within a mix of seemingly harmless odors.

To prevent CO poisoning, ensure that the SHS exhaust stack sections fit together snugly and that the exhaust gases are properly vented through the roof of the shelter.

The best way to prevent CO poisoning is to keep the SHS in good working order. Ensure that all possible sources of CO leakage have been repaired and that the operating space is well ventilated.

Before the heater can be used, the stack must be assembled outside the shelter, installed in the heater stack adapter and stabilized with the provided guy lines.

The stack assembly is provided as six separate stack sections nested inside one another. Disassemble the individual sections of the stack assembly **(1)** and organize them by number on the ground. Take note that the number **(2)** of each stack section is stamped into the side of the section.

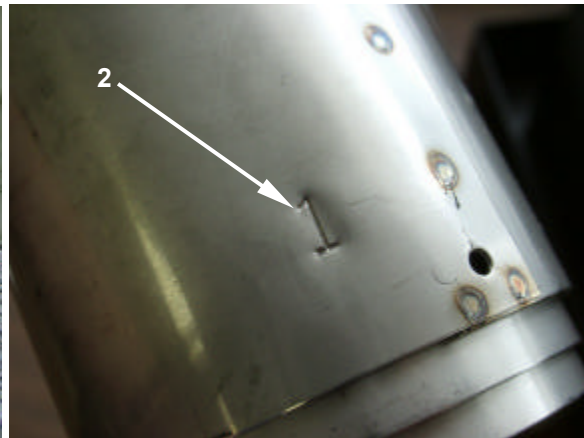

Locate sections "1" and "2" and place the crimped end of section "1" into the uncrimped end of section "2". Engage the two sections and push them firmly together. Ensure that the sections go together securely.

Locate the section numbered "3" and install it on the crimped end of section "2". Press together securely.

Continue assembling the remaining sections until all six sections are in place. Ensure that the stack is straight and that all sections fit together securely.

If not already done, tie one end of each guy line (1) through the loop (2) on each of the three wire ropes (3) located on the rain cap (4) with a double overhand knot.

Install the rain cap (4) onto the top of section "6" (5). Push the rain cap (4) onto the end of the section securely.



Raise the assembled stack and rain cap assembly (1) and position it over the tent collar assembly (2). Lower the stack assembly (1) down into the tent collar opening (2) and into the stack adapter (3) on the top of the heater.

Ensure that the stack and rain cap assembly (1) is reasonably secure and enter the shelter. Inspect the connection between stack section "1" (4) and the stack adapter (3) on the top of the heater. Be sure that stack section "1" is securely installed in the stack adapter (3).

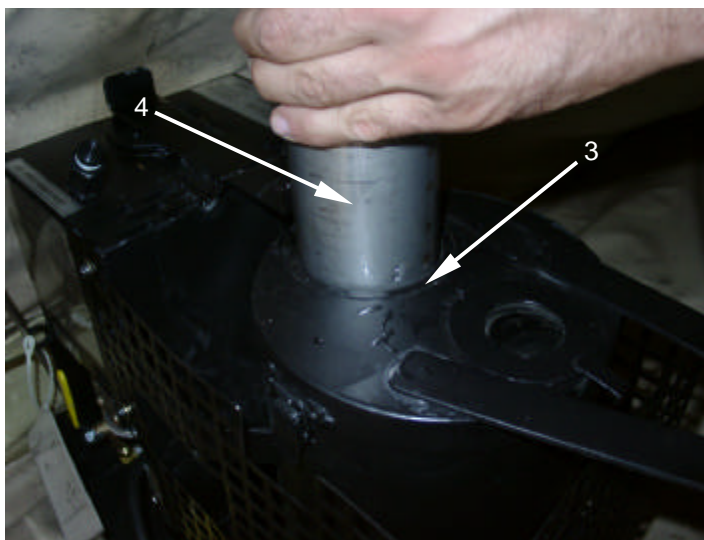

WARNING!
Fire Danger

It is important to stake the exhaust stack securely since this will keep the exhaust stack vertical and seated firmly within the stack adapter with a downward force. This also stabilizes the heater and helps prevent it from being knocked over if bumped by equipment or people inside the shelter. Secure staking assists in holding the shelter roof and sides in position during windy conditions. If the guy lines are improperly spaced and/or loose, the shelter roof and sides can flap during snowy, windy conditions. If the shelter itself is not taut, the roof and side walls can flap, getting quite close to the heater, creating a fire danger.

Outside the shelter, secure each of the three guy lines (1) to the "D" rings (2) on the tent stake straps (3) with a double overhand knot. Pull each guy line taut but ensure that the stack assembly (4) remains vertical. Do not pull the guy line so tight that the stack assembly begins to tip.

While standing on the side of the tent near the stack assembly, attach the first guy line to the "D" ring on the left tent stake strap (5).

Attach the second guy line to the "D" ring on the right tent stake strap (6).

The third guy line (7) extends over the top of the shelter and is secured to the stake strap (8) located nearest shelter door.



OPERATING THE SPACE HEATER SMALL

Before operating the SHS, be sure to have matches and a small supply of tissue available inside the shelter.

STARTING THE HEATER



WARNING! Fire or Explosion

Never attempt to light a heater that may still be hot. Allow the heater to cool sufficiently before lighting. Lighting a heater that is still hot may result in fire/explosion!

Preparing the SHS. Place a small section of petroleum absorbent mat in front of the heater and have a rag available to wipe up any spilled fuel.

Open the air vent (1) on the air vent/primer port two to three turns. If air vent is not opened, fuel flow to heater will stop and the fire will go out.

Ensure that the fuel quick disconnect (2) is securely engaged.

Rotate the burner control (3) up or down as needed to position the indicator arrow (4) on setting # 5 of the burner rate indicator scale (5).

Open the fuel shut-off valve (6) by rotating the valve handle upward as indicated on the fuel shut-off valve label (7).



Priming the SHS. Take a short length of tissue (1) and roll it tightly into a ball. Place the ball of paper on top of the heater near the edge of the sight glass (2).

Lift the sight glass (2) slightly and move it off to one side.

Loosen and remove air vent/primer port assembly (3), on the top of the fuel tank, by rotating the two arms counterclockwise.

Remove the priming bulb (4) from its stowage position on the side of the heater and insert the tube into the primer port opening (5). Squeeze the priming bulb to fill with fuel.

Remove the priming bulb from the primer port opening and insert the end of the priming bulb into the sight glass opening (6). Position the priming bulb tip in the bottom center of the burner. Squeeze the priming bulb to inject fuel into the bottom of the burner shell assembly.

Using the remaining small amount of fuel left in the primer bulb (4), dampen the tissue (1).

Place the priming bulb back into its stowage position and screw air vent/primer port assembly (3) back onto the heater.

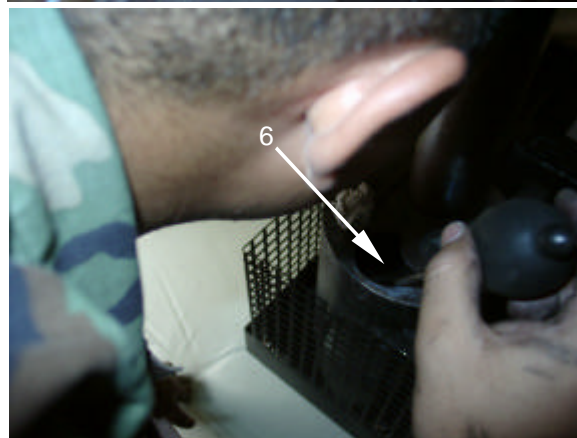
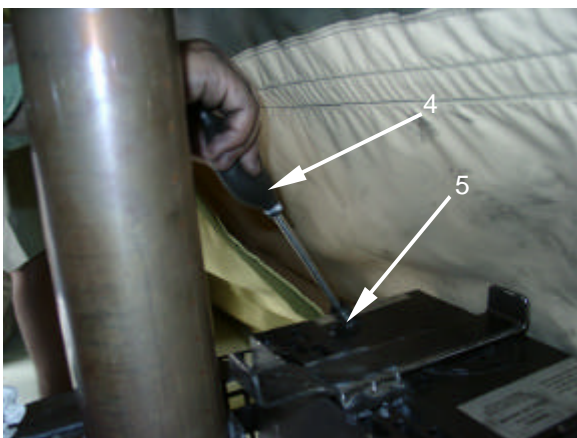
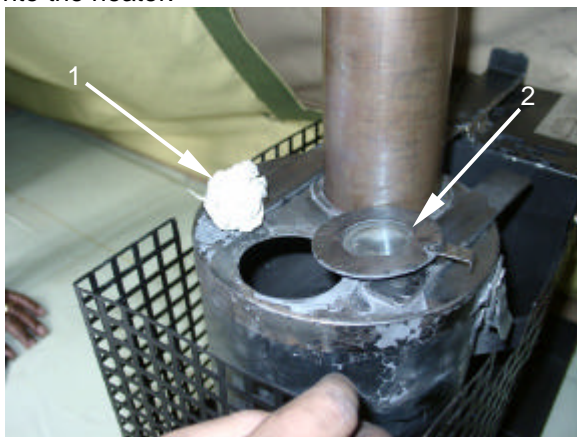

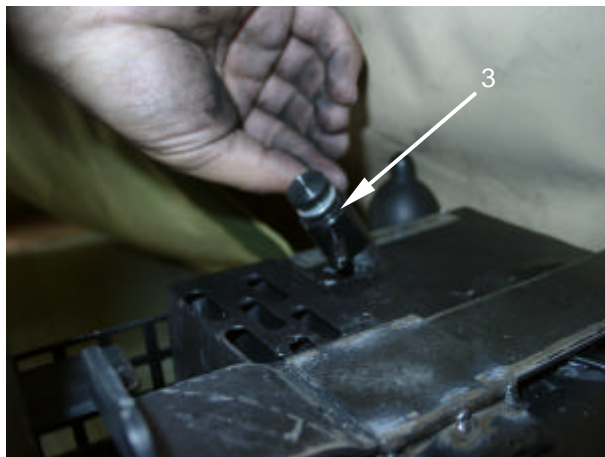
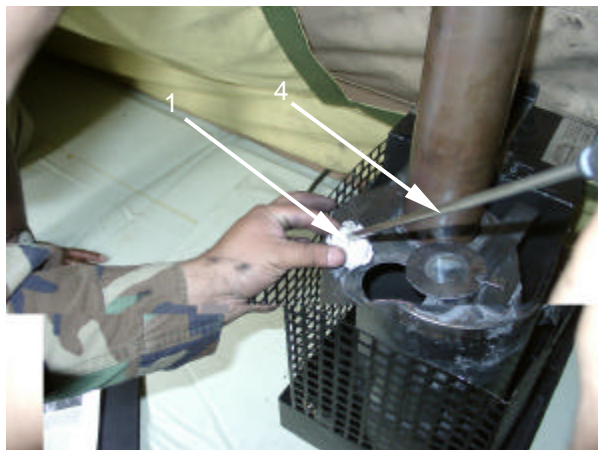

Lighting the Heater. Light the fuel soaked toilet tissue (1) with a match and push it into the sight glass opening (2) so that it falls to the bottom of the burner where it can ignite the priming fuel. Use the primer bulb rod if necessary to push the burning tissue to the bottom of the burner. Make sure that the burning tissue remains down in the burner. Close the sight glass lid (3).

If the heater does not start or goes out, allow the unit to cool completely and repeat the starting procedure. Do not attempt to relight a hot heater.

When the heater has warmed up sufficiently and begins to give off heat (approximately 5-10 minutes), gradually adjust the burner rate control (4) to desired heat output. For light fuels and usual conditions (i.e. JP-8 and kerosene) use lower settings (i.e. Settings 1-5). Heavier fuels (i.e. DF-2) can operate on higher settings.

Be sure to perform "DURING Operation" Preventive Maintenance Checks and Services (PMCS) as detailed in WP 0010 while the heater is in operation.

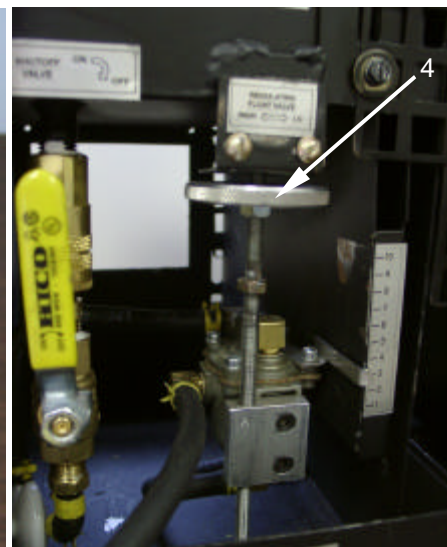
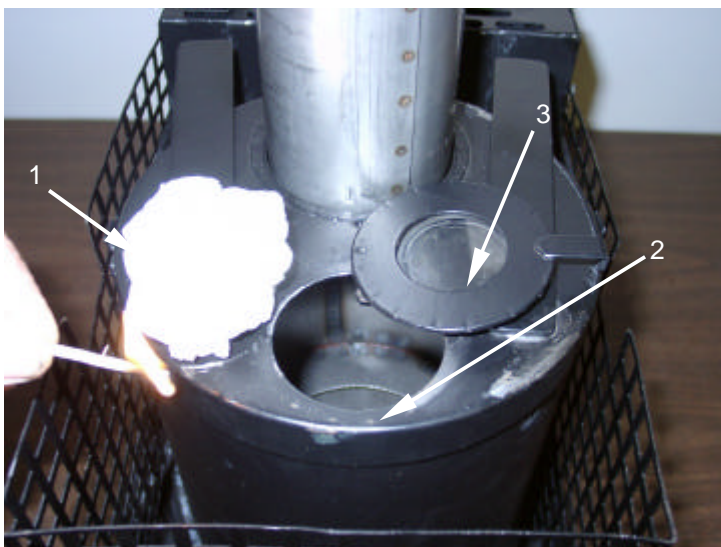

SHUTDOWN

To shutdown the SHS, move the fuel Shut-off valve **(1)** to the OFF position as indicated on the Fuel Shut-off Label. and close the air vent **(2)** by turning clockwise. It may require several minutes for all available fuel to burn and the heater extinguish.

Allow equipment to cool down. Perform "AFTER OPERATION" PMCS as detailed in WP 0010.



REFUELING



WARNING! Fire or Explosion

Do not attempt to refuel a hot space heater. Allow the SHS to cool completely before handling or refueling.

The SHS should never be refueled inside the shelter.

Shutdown the heater as described in the previous section. After the heater is completely cool, place a rag or section of petroleum absorbent mat to the side of the heater.

Remove the end of the stack assembly **(1)** from the stack adapter **(2)** on the top of the heater and lower the stack assembly on the right side of the heater and onto the rag or petroleum absorbent mat.

Pull the overflow hose **(3)** inside the tent making sure not to allow any drops of fuel to spill on the shelter floor. Coil the overflow hose and stow in the bottom portion of the heater.

Remove the heater from the shelter and refuel in accordance with the section of this work package entitled "Fueling the SHS".

Once the heater has been refueled, return the heater to its position inside the shelter. Install the stack assembly into the stack adapter and redeploy the overflow hose as detailed earlier.

If heat is desired, prime, light, and operate the heater as detailed earlier in this work package.

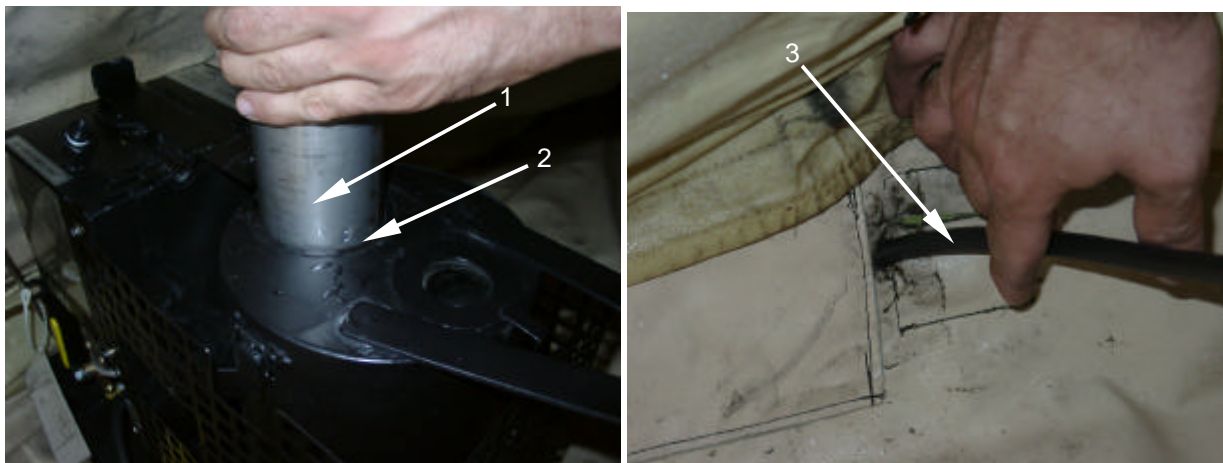

USING AN EXTERNAL FUEL SUPPLY



WARNING! Fire or Explosion

Do not attempt to fuel a hot space heater. Shut-down the heater and allow the SHS to cool completely before handling or fueling from an external supply.

In addition to its internal fuel tank, the Space Heater Small is equipped to accept an external fuel supply such as a standard five gallon fuel can. Using an external fuel supply will greatly extend the operating time of the heater. External fuel supply usage is optional and no external fuel supply components are included with the heater.

To use an external fuel supply, select and set up a fuel supply site at least seven feet from the shelter in accordance with safety and environmental guidelines. **Ensure that the priming valve on the fuel hose is closed by tightening in the clockwise direction.** Route the fuel supply hose from the inside of the tent through the small opening on the side of the shelter that is also used for the overflow hose. Lay the fuel hose out to the fuel supply site, making sure that the hose is not kinked in any way.

Ensure that the fuel shut-off valve (1) on the heater is in the OFF position as shown on the fuel shut-off label.

Pull back the outer collar (2) of the female portion (3) of the fuel quick disconnect located just above the fuel shut-off valve (1) and separate the female portion (3) of the fuel quick disconnect from the male portion (4) connected to the fuel shut-off valve (1).

Insert the female end (5) of the external fuel supply hose into the male portion (4) of the fuel quick disconnect of the fuel shut-off valve and push together while pulling back on the outer collar. Push the two connectors firmly together and release the outer connector. Tug on the two connectors to ensure that they are securely engaged.

Outside the tent, connect the fuel hose to the gravity feed adapter and mount the fuel can in the fuel can stand.

Inside the tent, place a small section of petroleum absorbent mat in front of the heater and have a rag available to wipe up any spilled fuel.

Open the air vent (6) on the air vent/primer port two to three turns. If air vent is not opened, fuel flow to heater will stop and the fire will go out.

Rotate the burner control (7) up or down as needed to position the indicator arrow (8) on setting # 5 of the burner rate indicator scale (9).

Open the fuel shut-off valve (1) by rotating the valve handle so that the handle is parallel to the fuel hose.

Take a short length of tissue (10) and roll it tightly into a ball. Place the ball of paper on top of the heater near the edge of the sight glass (11).

Lift the sight glass (11) slightly and move it off to one side.

Priming The SHS With An External Fuel Supply. Place a section of petroleum absorbent material under the priming valve (12) located on the fuel hose.

Open the priming valve (12) on the fuel hose slightly and fill the small stainless steel cup provided on the fuel hose with fuel. Be sure to direct the opening of the priming valve directly down into the cup to avoid splashing and/or spilling of fuel.

Pour the priming fuel into the base of the burner. Use two cups of priming fuel in extremely cold conditions.

Wipe the remaining fuel from the cup with the tissue prepared previously and place it near the sight glass opening.

Light and operate the heater as detailed in the previous section of this work package entitled "Lighting the SHS".

After use, shut the heater down as detailed in the section entitled "Shutdown".



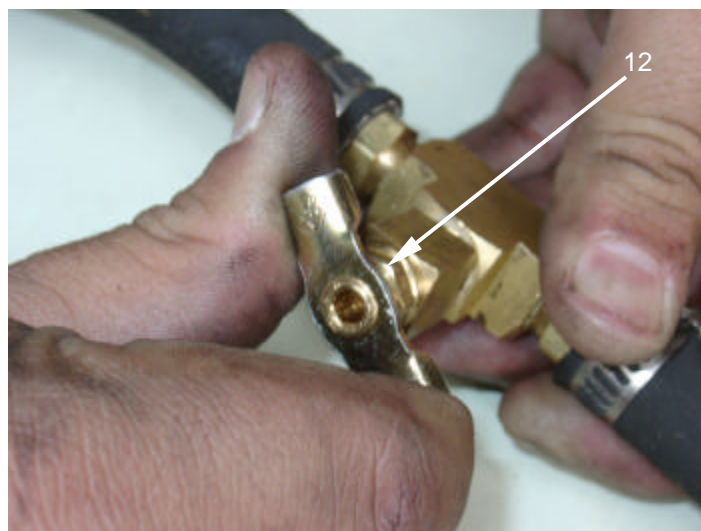
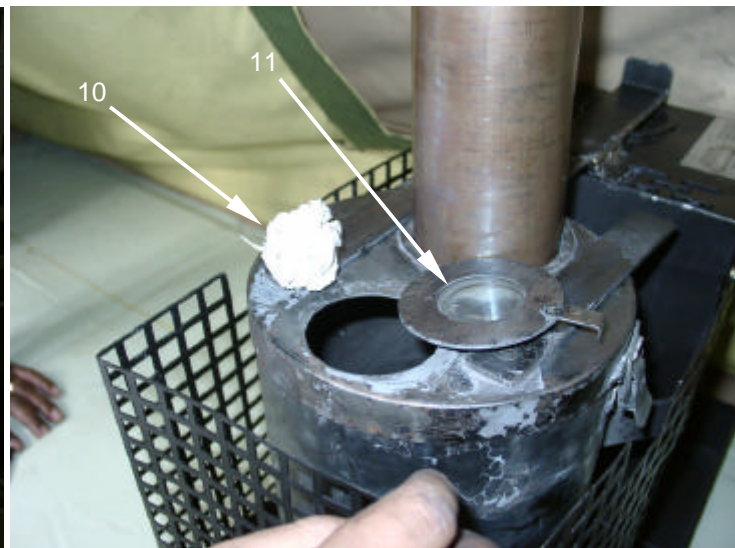
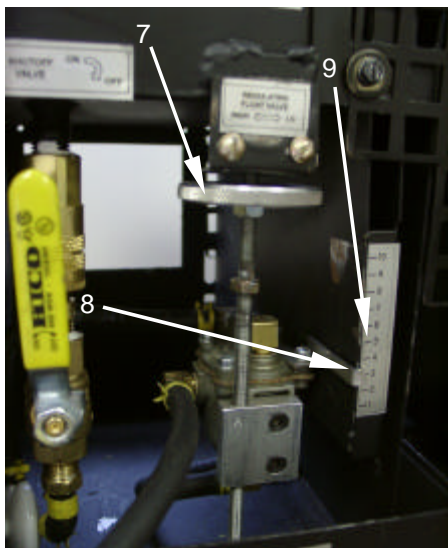
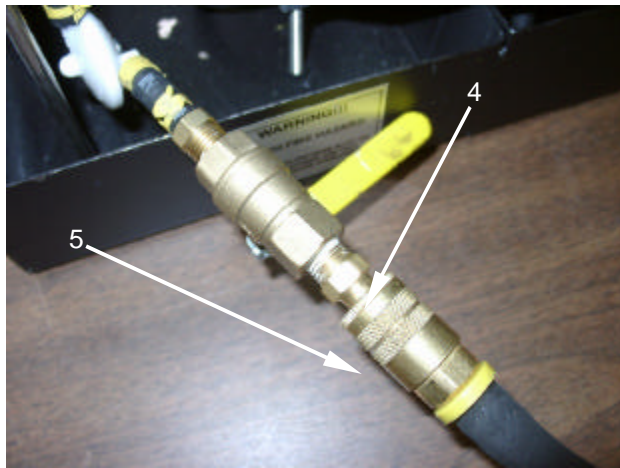

PREPARATION FOR MOVEMENT



WARNING! **Hot Surfaces**

Do not disassemble a hot heater. Allow the heater to cool completely before handling or moving. Handling a hot heater may result in severe burns.

Outside of the shelter, untie the stack cap assembly guy lines **(1)** from the loops on the tent stake straps **(2)** and lift the entire stack with attached rain cap assembly **(3)** from the roof opening **(4)**.

Inside the tent, pull the overflow hose **(5)** into the tent. Coil the hose and stow in the lower section of the heater **(6)**. Unroll the inner cotton liner flap **(7)** and secure around the outer edge with hook and pile fastener.

Remove the heater from the tent and place in a convenient location to allow stowage of heater components.

Outside the tent, remove the rain cap with attached guy lines **(8)** from the top stack section **(9)**. Coil up the guy lines **(10)** and stow the rain cap with attached guy lines **(8)** inside the lower heater **(11)**.

Disassemble each section of the stack assembly and nest the stack together for stowage. Referring to the numbers stamped on the side of each stack section, insert section "5" inside section "3". Place both sections inside section "1". Place the nested assembly **(12)** in the stowage area on the side **(13)** of the burner canister.

Now place section "6" inside section "4". Place both sections inside section "2". Place the second nested assembly in the stowage area **(14)** on the opposite side of the burner canister.

Loosen the tie straps **(15)** on the tent roof opening flap **(16)** located on the rain fly **(17)** and unroll the flap. Engage the hook and pile fastener **(18)** on the outer perimeter of the flap to the tent. Secure the top portion **(19)** of the flap.

Raise the rain fly **(17)** by disengaging the three hooks at the base and fold up to gain access to the roof flap on the outer tent wall **(20)**. Unroll and secure the tent roof opening flap on the outer tent wall as described above.

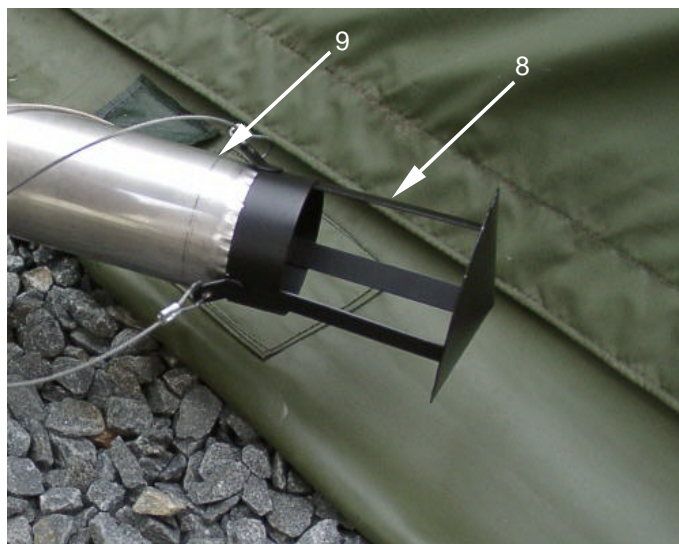
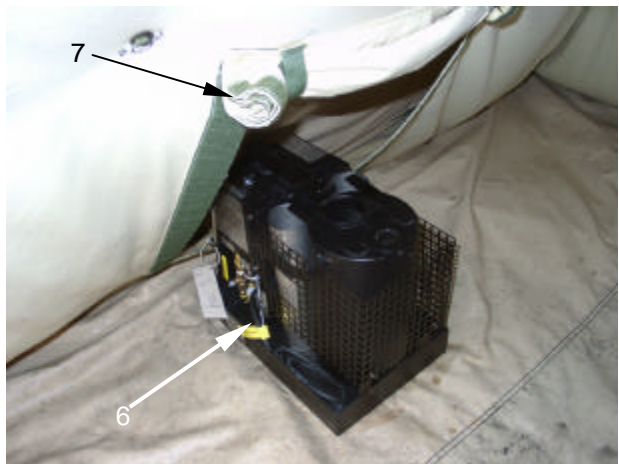
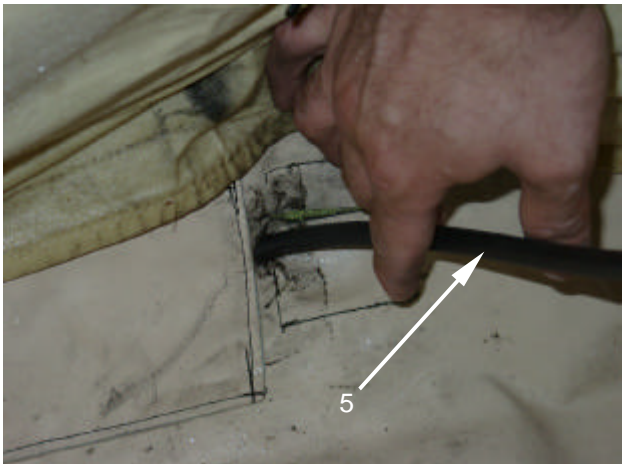

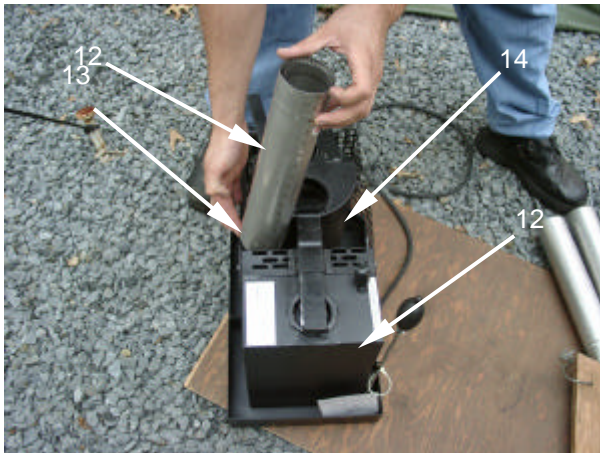
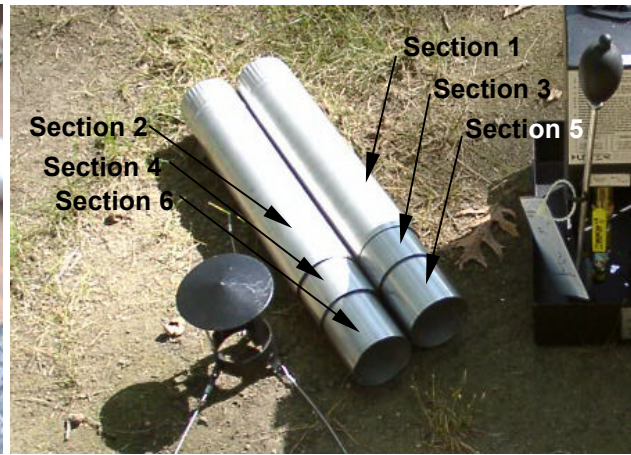
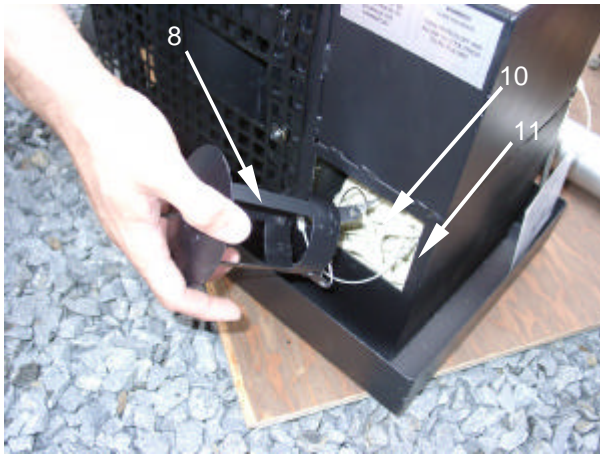

PREPARATION FOR STORAGE OR SHIPMENT

Heater must be shut down and disassembled as described in this work package.

Drain the fuel tank by removing the fuel cap and pouring the fuel from the heater into an approved container. Use the priming bulb to transfer any remaining fuel in the tank to the container. Replace the fuel cap on the heater.

Perform all AFTER OPERATION Preventive Maintenance Checks and Services (PMCS) as described in WP 0010.

Remove the tent collar assembly from the tent and stow between the heat shield and the burner canister.

If any maintenance is required at the unit level, refer to the heater to unit maintenance for repair prior to storage or shipment.

**SPACE HEATER SMALL (SHS)
OPERATION UNDER UNUSUAL CONDITIONS**

GENERAL

Refer to Operation Under Usual Conditions (WP 0005), for specific operating instructions, and use this work package for further instruction if operating the heater in unusual conditions. Read all sections which apply to the conditions to which your heater will be exposed.

**WARNING!
Carbon Monoxide**

During operation, the SHS produces harmful carbon monoxide (CO) and other gases. Carbon monoxide is a colorless, odorless, and tasteless gas. Mild cases of carbon monoxide poisoning can cause symptoms such as nausea, dizziness or headaches. Severe cases of carbon monoxide poisoning can result in brain damage, heart damage or death. Remember that although CO has no telltale odor, it may mix with other odors which mask its presence; therefore, CO can be present within a mix of seemingly harmless odors.

To prevent CO poisoning, ensure that the SHS exhaust stack sections fit together snugly and that the exhaust gases are properly vented through the roof of the shelter.

The best way to prevent CO poisoning is to keep the SHS in good working order. Ensure that all possible sources of CO leakage have been repaired and that the operating space is well ventilated.

OPERATION IN DUSTY OR SANDY CONDITIONS

Care should be exercised when using the SHS in sandy or dusty conditions to ensure that fuel tank and burner assembly remain free of sand. To prevent sand from contaminating the fuel tank and burner assembly, leave lid and lid assembly closed all times.

Keep lids installed tightly on all fuel containers.

OPERATION IN COLD CONDITIONS**WARNING!
Freeze Hazard**

Severe injury may occur to personnel handling metal parts without protective gloves when temperatures are below freezing. Skin may freeze upon contact and tear from the flesh.

Do not allow fuel to come in contact with bare skin. Even though fuel does not freeze, it is extremely cold and will burn exposed skin on contact. Wear protective gloves whenever handling or working with liquid fuel.

Do not handle metal components without protective gloves when temperatures are below freezing (32 degrees Fahrenheit).

When temperature is below -25 degrees Fahrenheit (-31 degrees Celsius), use JP-8 or DF-A fuel.

For light fuels (i.e. JP-8 and kerosene) use lower settings (i.e. Settings 1-5). Heavier fuels (i.e. DF-2) can operate on higher settings.

In extremely cold conditions, use two primer bulbs full of fuel to prime the heater.

OPERATION IN HIGH ALTITUDE CONDITIONS

Inspect heater operation more frequently.

Lower than normal operating settings of burner rate control may be desirable to prevent over firing and carbon buildup.

OPERATION IN RAINY OR HUMID CONDITIONS

If heater has been exposed to rain, drain any large water deposits before attempting to light.

Prevent fuel contamination by keeping lids tightly on fuel containers. Water in the fuel tank will cause the heater to sputter, pop, bang, and could possibly extinguish the flame.

OPERATION IN SALT WATER AREAS

Keep heater free from salt water contact as much as possible.

Wash heater frequently with fresh water if exposed to salt spray, to prevent corrosion.

OPERATION IN SNOWY OR SNOW-COVERED CONDITIONS

If tent is set up on large accumulations of snow, set heater on stones or boards to prevent it from sinking.

Do not allow snow to accumulate in large amounts (over six inches [15.3 centimeters]) on the side of the tent near the operating heater.

If heater has been exposed to the weather, remove any large deposits of snow and ice before operation.

Prevent fuel contamination by keeping lids tightly on fuel containers. Water in the fuel tank will cause the heater to sputter, pop, bang, and could possibly extinguish the flame.

For light fuels (i.e. JP-8 and kerosene) use lower settings (i.e. Settings 1-5). Heavier fuels (i.e. DF-2) can operate on higher settings.

In extremely cold conditions, use two primer bulbs full of fuel to prime the heater.

NBC DECONTAMINATION PROCEDURES

Perform immediate, operational or thorough decontamination procedures in accordance with FM 3-5 as the mission, resources and tactical situation permit.

**WARNING**

For "immediate decontamination procedures" use ONLY hot soapy water for deconning HOT surfaces of the heater and stack. Shut down and cool the heater for any additional decontamination procedures.

DO NOT SPRAY DS2 OR ANY OTHER COMBUSTIBLE DECONTAMINATION SOLUTIONS OR COMPOUNDS ON AN OPERATING HEATER OR STACK. (NOTE: DS2 has a flashpoint of 160 degrees F.)

THIS PAGE INTENTIONALLY LEFT BLANK

**SPACE HEATER SMALL (SHS)
OPERATOR LUBRICATION AND SERVICE PARTS INFORMATION**

LUBRICATION REQUIREMENTS

There are no lubrication requirements for the SHS.

SERVICE PARTS OVERPACK

There will not be any service overpack during initial fielding of the SHS.

THIS PAGE INTENTIONALLY LEFT BLANK

TM 10-4520-263-12&P

CHAPTER 3
OPERATOR TROUBLESHOOTING PROCEDURES
SPACE HEATER SMALL (SHS)

THIS PAGE INTENTIONALLY LEFT BLANK

**SPACE HEATER SMALL (SHS)
OPERATOR MALFUNCTION SYMPTOM INDEX**

INTRODUCTION TO TROUBLESHOOTING

The Malfunction Index lists common malfunctions that may occur during heater inspection and operation.

Find the malfunction the heater is having in the index and go to the given troubleshooting procedure in the following pages.

These charts cannot list all malfunctions that may occur, all tests or all inspections needed to find the fault, nor all actions required to correct the fault. If your malfunction is not listed in, or is not correctable through, this troubleshooting index, notify Unit Maintenance.

MALFUNCTION SYMPTOM INDEX

Malfunction or Symptom	Refer to Troubleshooting Procedure
Heater does not start	1
Heater does not work properly	2

THIS PAGE INTENTIONALLY LEFT BLANK

**SPACE HEATER SMALL (SHS)
OPERATOR TROUBLESHOOTING PROCEDURES**

TROUBLESHOOTING PROCEDURES

The troubleshooting procedures contain tables that list possible malfunctions, the tests or inspections to perform, and the corrective action required to return the SHS to normal operation. Perform the steps in the order they appear in the tables.

Each procedure is headed by an initial setup. This setup outlines what is needed as well as certain conditions which must be met before starting the task.

DO NOT START THE TASK UNTIL:

- You understand the task
- You understand what you are to do
- You understand what is needed to do the work
- You have the things you need

This manual cannot list all malfunctions that may occur, or all tests or inspections and corrective actions. If a malfunction is not listed or is not corrected by listed corrective actions, notify unit maintenance.

THIS WORK PACKAGE COVERS:
TROUBLESHOOTING PROCEDURES

Maintenance Level Operator	Materials/Parts Rags, Wiping (WP 0049 00, Item 1)
--------------------------------------	---

Table 1. Operator Troubleshooting Procedures

MALFUNCTION	TEST OR INSPECTION	CORRECTIVE ACTION
1. Heater does not start	<ol style="list-style-type: none"> 1. Check to see if fuel tank is empty. 2. Check to see if fuel shut off valve is set to ON. 3. Not enough or no primer fuel in bottom of burner. 4. Lighted tissue paper not placed in bottom of burner. 5. Air vent not open. 6. Air bubbles in fuel line. 7. Float stuck in an UP position. 	<p>Check fuel supply and replenish if necessary.</p> <p>Set fuel shut off valve to the ON position.</p> <p>Ensure that enough priming fuel is used prior to lighting the heater.</p> <p>Use priming rod to push lighted tissue paper to the bottom of the burner.</p> <p>Open air vent two to three turns.</p> <p>Shake the fuel lines to dislodge any air bubbles.</p> <p>Tap and/or shake the float assembly to free up the float.</p>
2. Heater does not operate properly.	<ol style="list-style-type: none"> 1. Check to see if fuel tank has been filled with authorized fuel and that the fuel is free of water, debris or contaminants. 2. Check the sections of the stack assembly for poor seals. 3. Check rain cap and stack assembly for heavy accumulations of snow or ice blocking rain cap. Check the interior of the rain cap and stack assembly sections for accumulation of creosote on inside surface. 	<p>Fill fuel tank with a clean, authorized fuel.</p> <p>Rotate the stack assembly sections to obtain tight seal. Replace a damaged stack assembly.</p> <div style="text-align: center;">  <p>WARNING Turn off heater and let cool.</p> </div> <p>Clean the interior of the rain cap and stack assembly. Refer to WP 0013 00.</p>

Table 1. Operator Troubleshooting Procedures

MALFUNCTION	TEST OR INSPECTION	CORRECTIVE ACTION
	4. Check for soot buildup inside the burner and especially underneath the burner high fire ring.	Clean out soot from under burner high fire ring and inside burner with a brush, rag, or gloves. Remove all accumulated soot.
	5. Check fuel line for blockage.	Replace fuel strainer.
	6. Downtube not properly seated.	Push downtube to bottom of burner.
	7. Air bubbles in fuel line.	Shake fuel lines to dislodge any air bubbles.
	8. Air vent is not open.	Open air vent two to three turns.

END OF WORK PACKAGE

THIS PAGE INTENTIONALLY LEFT BLANK

TM 10-4520-263-12&P

CHAPTER 4

**OPERATOR
MAINTENANCE INSTRUCTIONS**

SPACE HEATER SMALL (SHS)

THIS PAGE INTENTIONALLY LEFT BLANK

SPACE HEATER SMALL (SHS)

NSN 4520-01-478-9207

OPERATOR PREVENTIVE MAINTENANCE CHECKS AND SERVICES

INITIAL SETUP:

Tools

Personnel Required

One

Materials/Parts

Equipment Condition

Rags (WP 0049 00, Item 1)

SHS Shut-down and cool

INTRODUCTION

Preventive Maintenance Checks and Services (PMCS) are performed to keep the SHS and its associated equipment in good operating condition. The checks are used to find, correct, or report problems. Operator personnel are to do the PMCS jobs as shown in the PMCS table. PMCS are done every day the SHS is operated, using the PMCS table. Pay attention to WARNING and CAUTION statements. A WARNING means someone could be hurt. A CAUTION means equipment could be damaged.

Before you begin using the SHS, do **Before PMCS**

During use of the SHS, do **During PMCS**

After using the SHS, do **After PMCS**

Once a week, do **Weekly PMCS** if the SHS has been in use

Do **Monthly PMCS** once a month if the SHS has been in use

If you find something wrong when performing PMCS, fix it using troubleshooting and/or maintenance procedures.

The right-hand column of the PMCS table lists conditions that make the SHS not fully mission capable. Write up the faults that cannot be repaired on DA Form 2404 for unit maintenance. For further information on how to use this form, see DA PAM 738-750.

If tools that are required to perform PMCS are not listed in procedures, notify your superior.

INSPECTION

Look for signs of trouble. Senses help here. You can feel, smell, hear, or see many problems that can be eliminated before they get worse. Inspect to see if items are in good condition. Are components correctly installed and secured? Is any damage to the frame or components visible? Correct any faults or notify unit maintenance.

There are some common items to check on the SHS and associated equipment. These include the following:

- Proper operation of SHS fuel control valve and burner rate control.
- Condition of overflow hose
- Condition of stack assembly, rain cap, and guy lines
- Accumulation of carbon deposits inside burner canister

LUBRICATION SERVICE INTERVALS

All metal heater components should be wiped down with a rag before storage or after cleaning to prevent rust.

CLEANING

Proper cleaning of the SHS and components is an integral part of maintenance. It will help prevent possible problems in the future, so make it a habit to clean the SHS and its components whenever necessary.

The heater frame can be cleaned with a rag. Wipe down overflow hose with a rag.

After operating the heater, be sure to clean the inside of the stack assembly sections with a rag or brush to remove any creosote buildup that may occur.

THIS SECTION COVERS:

Before Operation PMCS Checks and Services

INITIAL SETUP:

SHS Shutdown and Cool

Maintenance Level

Operator

Materials

Wiping Rags (WP 0049 00, Item 1)

Table 1. Preventive Maintenance Checks and Services for SHS

ITEM NO.	INTERVAL	ITEM TO BE CHECKED OR SERVICED	PROCEDURE	EQUIPMENT NOT READY/ AVAILABLE IF:
1	Before	Rain cap and nested stack assemblies	Check inside of stack sections (1) and rain cap (2) for thick deposits of carbon/soot, and clean if necessary. Check for cracked sections or bent flanges which may cause the leakage of exhaust gases into heated space during heater operation.	Stack or rain cap assembly have an accumulation of carbon/soot which would impair operation or cause a fire inside the stack and rain cap during operation. Cracks exist or flange bent.
2	Before	Tent lines and wire ropes	Check for frayed or cut guy lines (3) and wire ropes (4) .	Tent lines or wire ropes frayed or cut.
3	Before	Heater body assembly	Clean carbon/soot deposits from heater body assembly (5) . Check that latches (6) for lid assembly (7) open and shut properly, and that stack adaptor assembly (8) is not bent.	Carbon/soot deposits from last operation have not been removed; latches for lid assembly do not open, or do not shut fully; stack adaptor assembly will not accommodate stack assembly.
4	Before	Canister lid assembly	Check that canister lid assembly (7) is not bent, and that it does not have holes in it.	Canister lid assembly bent or has holes in it which would prevent it from sealing off air leaks.

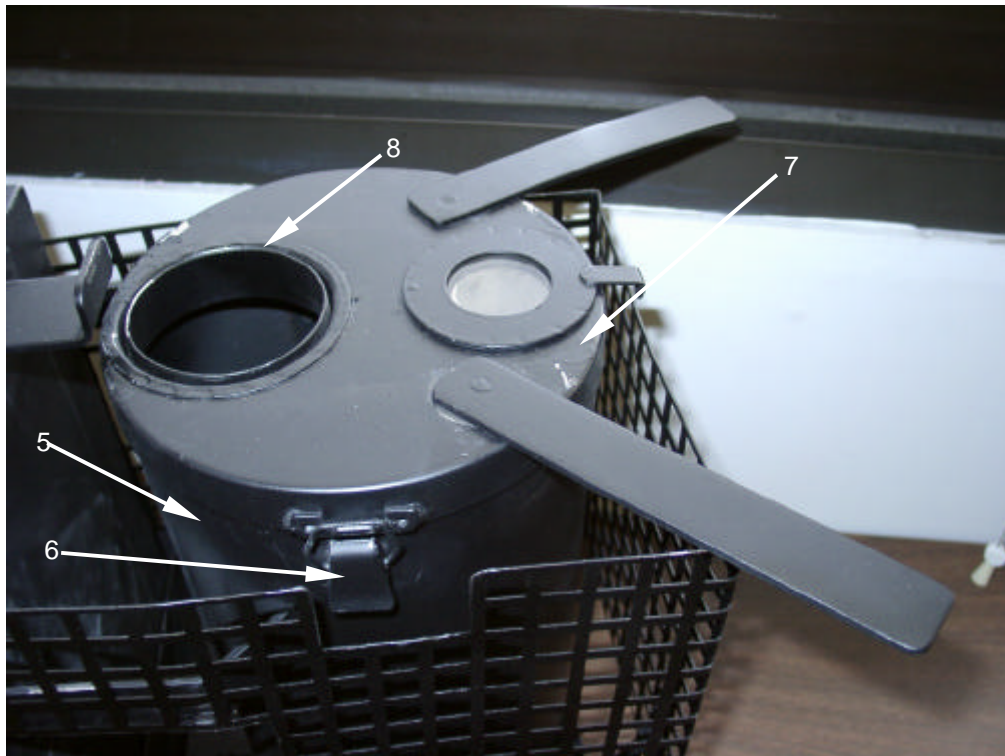
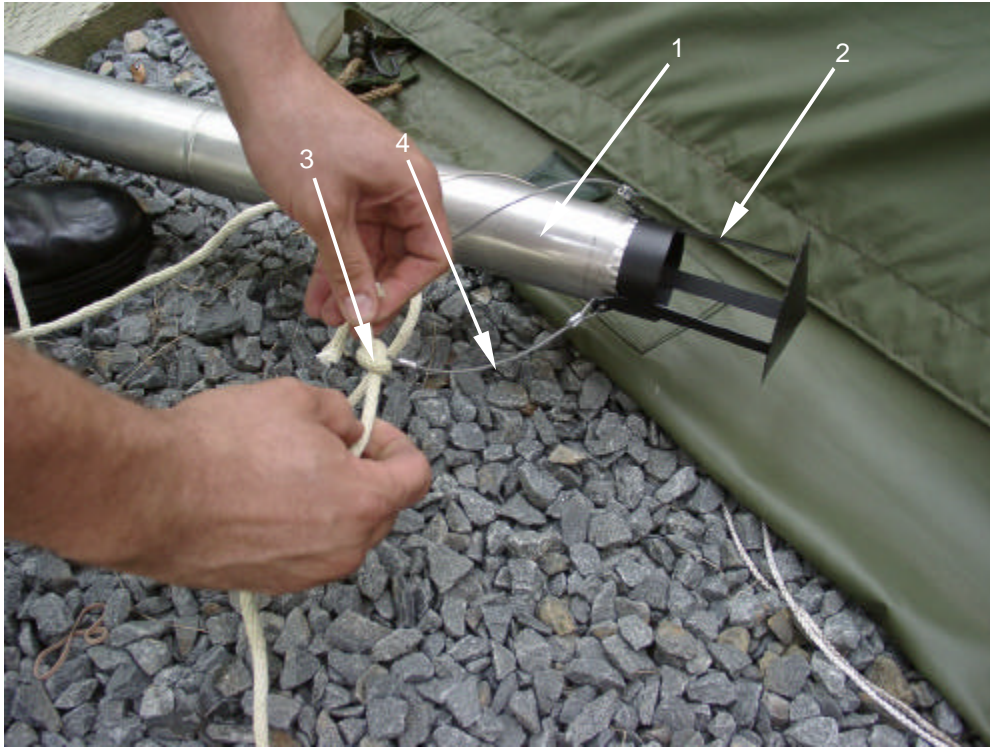

Table 1. Preventive Maintenance Checks and Services for SHS - continued

ITEM NO.	INTERVAL	ITEM TO BE CHECKED OR SERVICED	PROCEDURE	EQUIPMENT NOT READY/ AVAILABLE IF:
5	Before	Burner shell assembly	Check down tube assembly (1) and inside of burner shell assembly (2) and especially under the high fire ring for thick carbon/soot deposits. Clean if necessary. Check both assemblies, (1) and (2) , for cracked metal.	Down tube assembly is cracked or plugged and/or burner assembly holes are blocked.
6	Before	Fuel Shut-off Valve	Check for bent/damaged valve (3) .	Valve is damaged.
7	Before	Burner Rate Control	Check for bent/damaged control (4) and/or threaded shaft (5) . Ensure that burner rate indicator arrow is correctly aligned with indicator scale.	Burner rate control will not rotate and/or move up and down. Burner rate indicator arrow is damaged or misaligned with indicator scale.
8	Before	Overflow hose	Check for cuts or swollen areas in overflow hose walls (6) .	Hose is cut or has swollen areas.
9	Before	Fuel Tank QD Connector	Inspect the fuel tank QD connector (7) for any damage to the outer collar that would prevent the fuel tank QD connector from engaging properly to the fuel shut-off valve (3) . Ensure that there are no leaks from the connector (7) . Ensure that there is no buildup of fuel in the base tray.	Fuel tank QD connector leaks or will not engage properly with connector on fuel shut-off valve. Fuel is leaking and accumulating in the base tray.
10	Before	Fuel Strainer Assembly	Inspect the fuel strainer (8) assembly for cracks, leaks, or other damage that would prevent the fuel strainer from operating properly.	Fuel strainer cracked or leaking. Fuel strainer clogged so as to prevent the flow of fuel.
11	Before	Heat Shield Assembly	Inspect the heat shield (9) assembly for cracks or other damage that would prevent the heat shield from properly protecting the user from the heater canister (10) .	Heat shield missing or damaged so severely that it will not prevent the heater canister from coming in contact with bare skin.
12	Before	Tent Collar Assembly	Inspect the tent collar assembly (11) for cracks or other damage that would prevent the tent collar assembly from properly protecting the shelter from the heat of the stack assembly. Make sure that all wing nuts (12) are installed.	Tent collar bent, cracked, or otherwise damaged preventing the stack assembly from passing through the tent opening. Tent collar assembly missing.

Table 1. Preventive Maintenance Checks and Services for SHS - continued

ITEM NO.	INTERVAL	ITEM TO BE CHECKED OR SERVICED	PROCEDURE	EQUIPMENT NOT READY/ AVAILABLE IF:
13	Before	Labels	Inspect all labels (13) to ensure that they are not damaged, lost, or unreadable in any way.	Labels missing or damaged.
14	Before	Stack Lock Assy	Check to ensure that stack lock assembly (14) is not missing or damaged.	Stack lock assembly missing or damaged, preventing it from sliding over the stack opening and/or fuel cap.



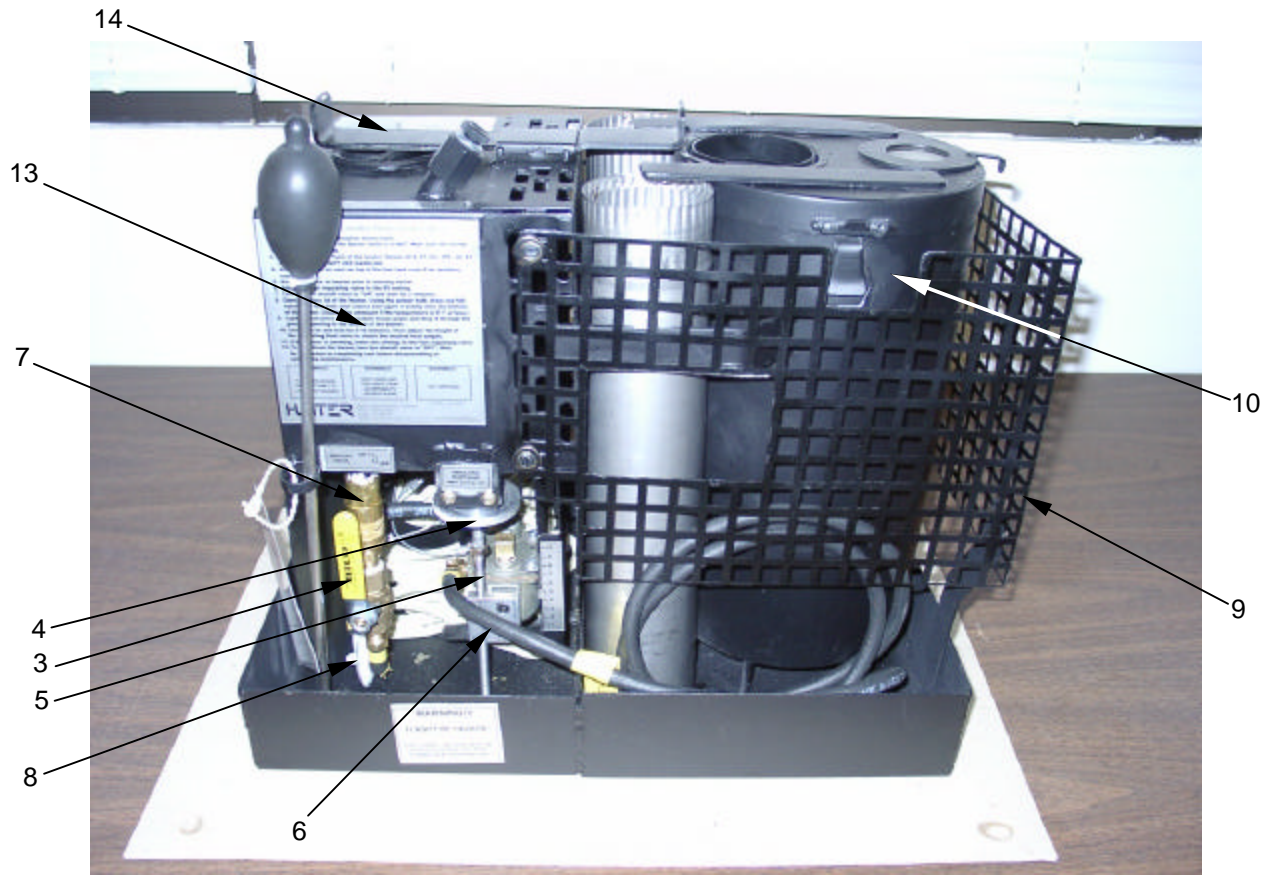
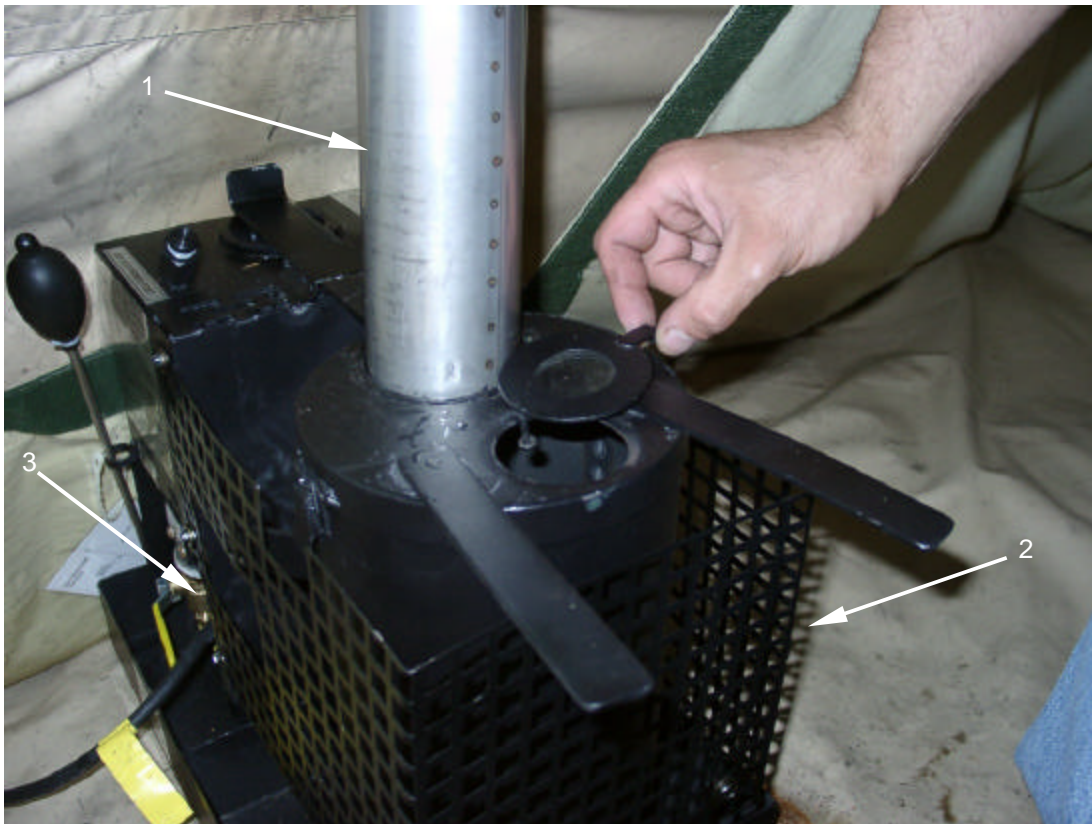

Table 1. Preventive Maintenance Checks and Services for SHS - continued

ITEM NO.	INTERVAL	ITEM TO BE CHECKED OR SERVICED	PROCEDURE	EQUIPMENT NOT READY/ AVAILABLE IF:
15	During	Nested stack assembly	Check stack assembly (1) for smoke leakage inside heated space.	Stack assembly leaks smoke into heated space.
16	During	Heater body assembly	Check heater body (2) for smoke leakage inside heated space.	Heater body leaks smoke into operating space.
17	During	Fittings	Check fittings (3) for fuel leakage.	Fittings have fuel leaks.



MANDATORY REPLACEMENT PARTS

The Space Heater Small has no mandatory replacement parts.

END OF WORK PACKAGE

THIS PAGE INTENTIONALLY LEFT BLANK

OPERATOR MAINTENANCE
SPACE HEATER SMALL (SHS)
NSN 4520-01-478-9207

INITIAL SETUP:**Tools****Personnel Required**

One

Materials/Parts**Equipment Condition**

SHS shutdown and cool (WP 0005 00)

INTRODUCTION

This section contains Operator Maintenance applicable to the SHS as authorized by the Maintenance Allocation Chart (MAC) in WP 0029 of this manual.

All maintenance procedures in this section can be performed by one person unless otherwise indicated.

Read all **WARNINGS**, **CAUTIONS**, and **NOTES** carefully before attempting the procedures. This includes the warnings at the front of this manual.

Each maintenance item will include a heading which lists the action to be taken, the tools and parts/materials required, and the condition the equipment must be in to perform the action.

END OF WORK PACKAGE

THIS PAGE INTENTIONALLY LEFT BLANK

**SPACE HEATER SMALL (SHS)
SERVICE UPON RECEIPT**

SERVICE UPON RECEIPT**GENERAL**

The heaters are shipped in standard type corrugated cardboard boxes. All components to the heaters are stowed within the heater body. The Unit Maintenance technician should inspect the equipment before it is used. Following is a list of functions which must be performed upon receipt of the SHS:

Unpacking. Before operation, heaters must be unpacked and cleaned of packing material and other foreign debris, and serviced in accordance with PMCS Table 1, WP 0010 00.

Inspection. The equipment must be inspected for damage incurred during shipment. If the equipment has been damaged in shipment, report the damage on SF 364, Report of Discrepancy.

Packing list verification. Check the equipment against the packing list to see if the shipment is complete. Report all discrepancies in accordance with DA PAM 738-750.

Verification of equipment modifications. Check to see whether the equipment has been modified.

Pre-operation services. Service damaged equipment, as necessary, using Operator Maintenance (Chapter 4) and/or Unit Maintenance procedures (Chapter 5) to restore equipment to operable condition.

Break-in Period. The Space Heater Small should be set up and operated for a break-in period of 1 to 2 hours in a well ventilated area so that any fumes generated by newly painted parts can escape.

THIS PAGE INTENTIONALLY LEFT BLANK

SPACE HEATER SMALL (SHS)

NSN 4520-01-478-9207

SPACE HEATER SMALL
SERVICE

INITIAL SETUP:

Tools

Wire brush or equivalent

Materials/Parts

Rags (WP 0049 00, Table 1, Item 1)

Personnel Required

One

Equipment Condition

SHS shut-down and cool (WP 0005 00)

GENERAL. This procedure is for cleaning the following SHS items: rain cap assembly, stack assembly, burner body assembly, lid assembly, hoses, and downtube assembly.



WARNING!

Fire or Explosion

Possible Equipment Damage

Certain heater components could be damaged by scraping or brushing. These components could malfunction and result in injury to personnel (for example, overflow hose could be damaged resulting in fuel leakage and fire).

Scrape or brush. Use a scraping tool or wire brush to remove all hardened deposits of soot, resin, or other foreign matter from the stack, lid assembly, and burner body components, inside and out.

Do not scrape or brush any rubber or plastic parts, instruction or I.D. plates, labeling or sightglass.

Clean burner assembly with a brush or dry rag. Carbon may build up after a period of use.

Wash. Wash exterior of heater and subassemblies (Overflow hose, Down-tube assembly, etc.) with a damp cloth. Wipe all surfaces to remove any soot or other residues. Wipe the heater body, burner shell assembly, rain cap assembly, and stack assembly with a damp cloth. Wipe all surfaces to remove any soot or other residue.

On the inside and outside of the heater body, rain cap assembly, and stack assembly, scrape or use a wire brush (or equivalent) to remove any dirt buildup which will not come off by wiping.

Dry heater body and metal components with a dry rag.

END OF WORK PACKAGE

THIS PAGE INTENTIONALLY LEFT BLANK

SPACE HEATER SMALL (SHS)

NSN 4520-01-478-9207

STACK ASSEMBLY
REPLACE

INITIAL SETUP:

Tools

Personnel Required

One

Materials/Parts

Equipment Condition

SHS shut-down and cool (WP 0005 00)

REPLACE

1. To replace the stack assembly **(1)**, release the three guys lines **(2)** that secure the rain cap **(3)** to the top of the stack assembly **(1)**.
2. Remove the stack assembly **(1)** from the stack adapter **(4)** on the top of the heater **(5)**.
3. Remove the rain cap assembly **(3)**.
4. Install the rain cap **(3)** on the top section of the new stack assembly **(1)**.
5. Install the new stack assembly **(1)** into the stack adapter **(4)** on the top of the heater **(5)**.
6. Install the guy lines **(2)** and secure the stack assembly **(1)**.

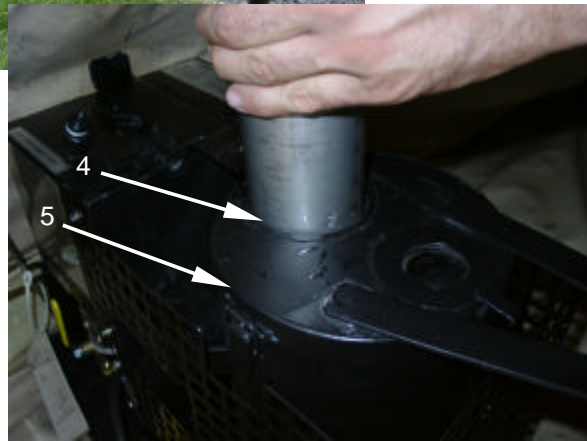

END OF WORK PACKAGE

OPERATOR MAINTENANCE**SPACE HEATER SMALL (SHS)**

NSN 4520-01-478-9207

**CANISTER LID ASSEMBLY
REPLACE**

INITIAL SETUP:**Tools****Personnel Required**

One

Materials/Parts**Equipment Condition**SHS shut-down and cool (WP 0005 00)

REPLACE

1. To replace a damaged canister lid assembly **(1)**, release the two latches **(2)** that secure the canister lid assembly **(1)** to the heater canister **(3)**.
2. Remove the damaged canister lid assembly **(1)** from the heater canister **(3)**. It may be necessary to rock the canister lid assembly slightly while pulling straight up to remove it from the heater canister.
3. Install the new canister lid assembly **(1)** on the heater canister **(3)** taking care to align the keepers **(4)** on the side of the canister lid assembly with the latches **(2)** on the side of the heater canister. Press the lid assembly down onto the heater canister. When properly aligned, the stack adapter opening **(5)** faces the fuel tank **(6)** and the latches **(2)** on the canister align with the keepers **(4)** on the canister lid assembly.
4. Secure the canister lid assembly latches **(2)**.

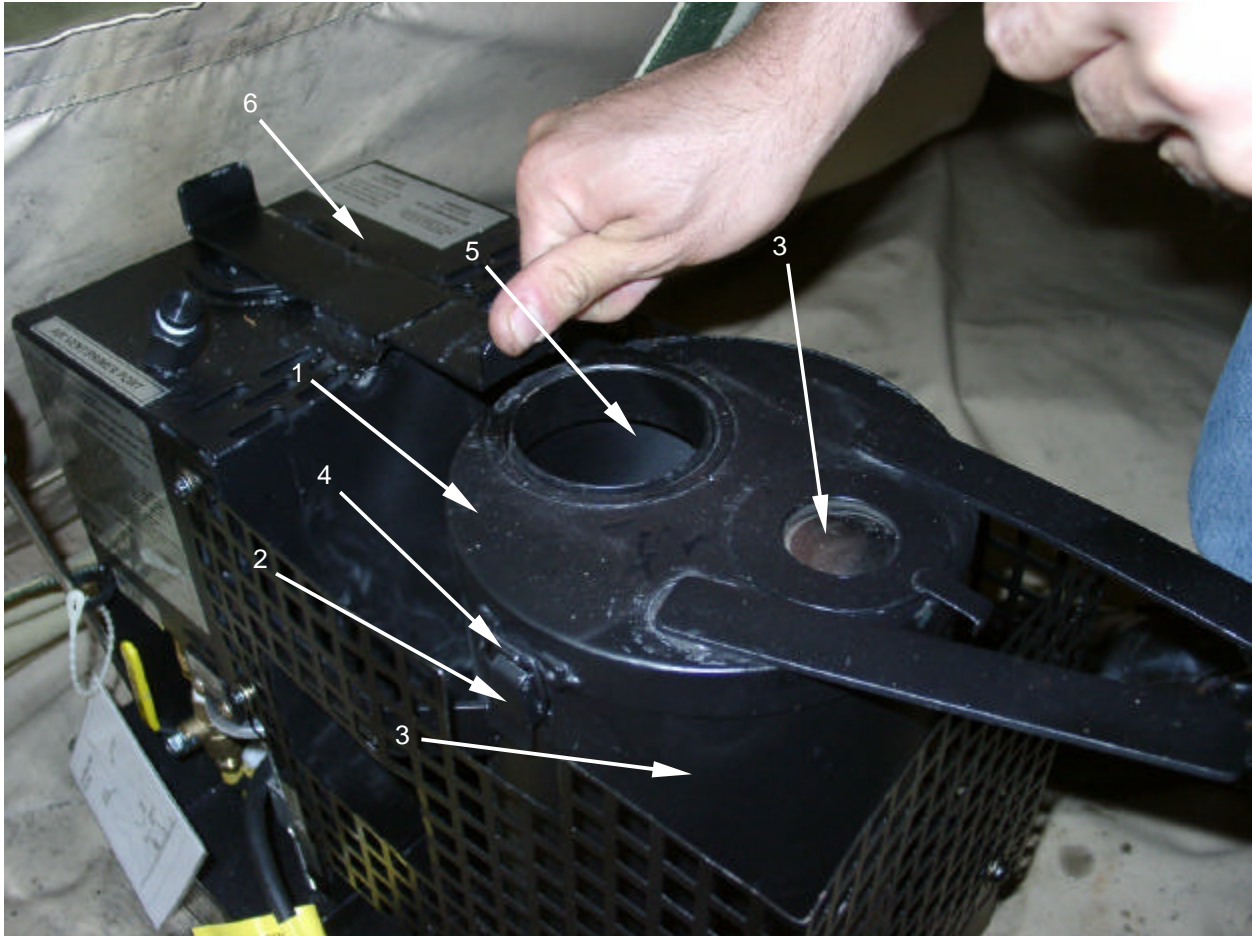

END OF WORK PACKAGE

SPACE HEATER SMALL (SHS)

NSN 4520-01-478-9207

BURNER SHELL AND DOWNTUBE ASSEMBLY
SERVICE, REPLACE

INITIAL SETUP:

Tools

Wire brush or equivalent (WP 0029 00, Table 2, Item 1)

Personnel Required

One

Materials/Parts

Wiping Rags (WP 0049 00, Table 1, Item 1)

Equipment Condition

SHS shut-down and cool (WP 0005 00)

SERVICE

1. Unlatch and remove canister lid assembly **(1)**.
2. Using a rag, reach into burner shell assembly **(2)** and pull the downtube assembly **(3)** up and off the up-tube **(4)**. Note that it may be necessary to twist the downtube slightly while pulling upward to remove due to soot deposits.
3. Use a wire brush or equivalent to loosen any heavy deposits of carbon or soot from inside the burner shell assembly **(2)**, and downtube assembly **(3)**.
4. Wipe the area under the high fire ring **(5)** with a rag to remove any carbon deposits.
5. Wipe the inside of burner shell assembly **(2)**, outside of up-tube **(4)** and the downtube assembly **(3)**, with a damp rag. Be sure to wipe out all loose debris in bottom of the burner shell assembly **(2)**.
6. Replace downtube **(3)** over the up-tube **(4)**. Make sure that downtube is properly seated at the bottom of the burner by pushing down firmly.
7. Install and latch the canister lid assembly **(1)**.

REPLACE

1. To replace a defective downtube **(3)**, remove the canister lid assembly **(1)** reach into the burner shell assembly **(2)**.
2. Grasp the downtube **(3)** with a rag and pull up with a slight twisting motion.
3. Remove the downtube **(3)** from the burner shell assembly **(2)**.
4. Install a new downtube **(3)** by sliding over the up-tube **(4)**. Make sure that downtube is properly seated at the bottom of the burner by pushing down firmly.
5. Install the canister lid assembly **(1)** taking care to align the keepers on the side of the lid assembly with the latches on the heater canister. Engage latches.

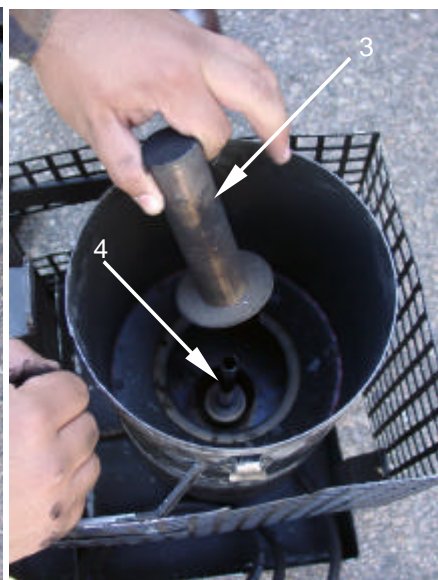
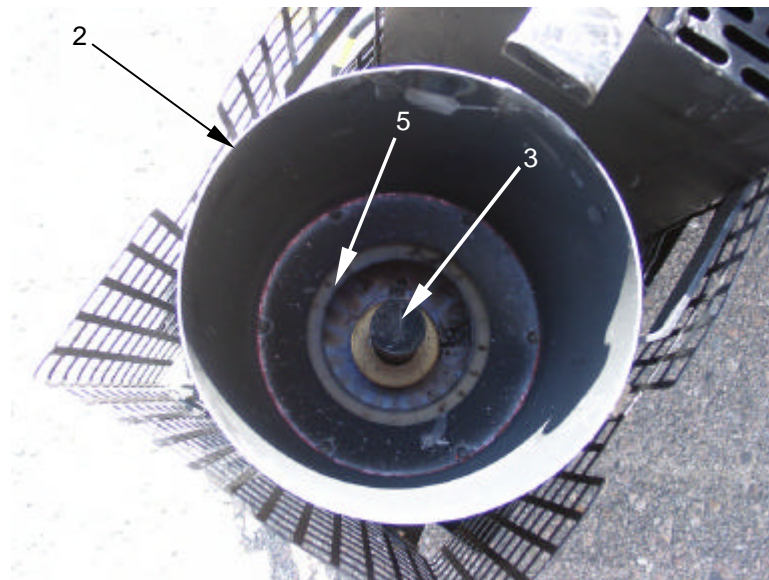

END OF WORK PACKAGE

OPERATOR MAINTENANCE**SPACE HEATER SMALL (SHS)**

NSN 4520-01-478-9207

**TENT COLLAR ASSEMBLY
REPLACE**

INITIAL SETUP:**Tools****Personnel Required**

One

Materials/Parts**Equipment Condition**SHS shut-down and cool (WP 0005)

REPLACE

1. To replace the tent collar assembly **(1)**. Release the guy lines and remove the stack assembly as detailed in the section of WP 0005 00 entitled "Preparation for Movement.
2. Inside the tent, loosen and remove the four wingnuts **(2)** that secure the two halves of the tent collar assembly.
3. Separate the inner portion of the tent collar assembly from the outer portion.
4. Outside the tent, reach under the rain fly near the roof opening and remove the outer portion of the tent collar assembly from the roof opening.
5. Separate the two halves of the new tent collar and install the portion with the threaded studs in the roof opening from outside the shelter.
6. Inside the tent, align and install the portion of the tent collar with the holes onto the portion with the threaded studs.
7. Install wingnuts **(2)** and secure.



END OF WORK PACKAGE

SPACE HEATER SMALL (SHS)

NSN 4520-01-478-9207

PREPARATION FOR SHIPMENT OR STORAGE

GENERAL

All Preventive Maintenance Checks and Services must be completed IAW PMCS WP 0010.

Correct all defects and failures, and apply all Modification Work Orders (MWO's).

Drain the fuel tank by removing the fuel cap and pouring the fuel from the heater into an approved container. Use the priming bulb to transfer any remaining fuel in the tank to the container. Replace the fuel cap on the heater.

Remove the tent collar assembly from the tent and stow between the heat shield and the burner canister.

Wipe down and dry all metal heater components inside and out with a rag. Failure to do so will encourage the components to rust.

Pack heater into original shipping carton, if available.

Attach equipment securely to vehicle when shipping to another site to prevent damage.

To prevent corrosion and other damage, do not store equipment in damp/wet areas for prolonged periods.

END OF WORK PACKAGE

THIS PAGE INTENTIONALLY LEFT BLANK

TM 10-4520-263-12&P

CHAPTER 5
UNIT MAINTENANCE
SPACE HEATER SMALL (SHS)

THIS PAGE INTENTIONALLY LEFT BLANK

**SPACE HEATER SMALL (SHS)
UNIT TROUBLESHOOTING PROCEDURES**

GENERAL

The Malfunction Index lists common malfunctions that may occur during heater inspection and operation.

Find the malfunction the heater is having in the index and go to the given troubleshooting paragraph in the following pages.

These charts cannot list all malfunctions that may occur, all tests or all inspections needed to find the fault, nor all actions required to correct the fault. If your malfunction is not listed in, or is not correctable through, this troubleshooting index, notify Unit Maintenance.

DO NOT START THE TASK UNTIL:

- You understand the task
- You understand what you are to do
- You understand what is needed to do the work
- You have the things you need

MALFUNCTION SYMPTOM INDEX

Malfunction or Symptom	Refer to Troubleshooting Procedure
Heater does not start or sputters and misfires during operation	1

THIS PROCEDURE COVERS:

Heater Does Not Start or Sputters and Misfires During Operation

INITIAL SETUP:

SHS Shutdown and Cool

Maintenance Level

Materials/Parts

Unit

None

Table 1. Unit Troubleshooting

MALFUNCTION	TEST OR INSPECTION	CORRECTIVE ACTION
1. Heater does not start	1. Check fuel line for blockage. 2. Verify that regulating float valve is functioning.	Replace fuel strainer as described in WP 0025. Replace regulating float valve as described in WP 0024.

END OF WORK PACKAGE

SPACE HEATER SMALL (SHS)

NSN 4520-01-478-9207

**SPACE HEATER SMALL
REPAIR**

INITIAL SETUP:

Tools

General Mechanic Tool Kit
(WP 0029 00, Table 2, Item 1)

Materials/Parts

Personnel Required

One

Equipment Condition

SHS shut-down and cool (WP 0005 00)

GENERAL

This procedure is for dent removal on the following SHS items: rain cap assembly, stack assembly, canister lid assembly, and burner body.



WARNING!

Carbon Monoxide

Bent or dented components may allow deadly carbon monoxide emissions into the operating space. Do not attempt to repair these components if leakage will not be completely stopped, or death may result due to inhalation of excessive amounts of carbon monoxide.

REPAIR

Use common tools (pliers, mallets, etc.) to remove, to the extent possible, any dents which impair operation of the heater.

Dent removal should only be carried out on the burner body, canister lid assembly, rain cap, stack assembly sections, and the heat shield.

Dent removal should be done short of replacing the item or items if and only if equipment operation will not be reduced. For example, if dent removal does not stop smoke leakage into the heated space, the faulty component or entire heater should then be replaced.

END OF WORK PACKAGE

THIS PAGE INTENTIONALLY LEFT BLANK

SPACE HEATER SMALL (SHS)

NSN 4520-01-478-9207

RAIN CAP ASSEMBLY
REPAIR, REPLACE

INITIAL SETUP:

Tools

General Mechanic Tool Kit
(WP 0029 00, Table 2, Item 1)

Personnel Required

One

Materials/Parts

Rope, wire (WP 0049 00, Table 1, Item 4)
Sleeves, swaging (WP 0049 00, Table 1, Item 5)
Rope, nylon (WP 0049 00, Table 1, Item 6)

Equipment Condition

SHS shut-down and cool (WP 0005 00)

REPAIR

1. To repair damaged wire rope **(1)**, cut unserviceable wire rope **(1)** from rain cap assembly **(2)**.
2. Cut 12 inch (30.5 centimeter) section of serviceable wire rope **(1)** from bulk wire rope supply.
3. Thread approximately 1½ inches (3.81 centimeters) of one end of wire rope **(1)** through a swaging sleeve **(3)**.
4. Thread the same end of the wire rope **(1)** through the rain cap assembly **(2)** perforation, and then back through the swaging sleeve **(3)** (a ¾ inch [1.91 centimeter] loop should be formed).
5. Crimp the swaging sleeve **(3)** down on the wire ropes **(1)** so that the loop is permanently closed.
6. Thread approximately 1-½ inches (3.81 centimeters) of the opposite end of wire rope **(1)** through the other swaging sleeve **(3)**.
7. Thread this same end of wire rope **(1)** back through the the swaging sleeve **(3)** (a ¾ inch [1.91 centimeter] loop should be formed).
8. Crimp the swaging sleeve **(3)** down on the wire ropes **(1)** so that the loop is permanently closed.
9. Repeat, as necessary, for other two wire ropes.
10. To repair damaged guy lines, cut unserviceable guy line **(4)** from wire rope **(1)**.
11. Cut 13 foot (4 meter) section of serviceable guy line **(4)** and tie to wire rope **(1)** through loop.

REPLACE

1. To replace a damaged and unservicable rain cap assembly **(2)**, remove the damaged rain cap from the top of the stack assembly.
2. Tie new guy lines **(4)** onto the loops **(3)** of the wire ropes **(1)** of the new rain cap.
3. Install new rain cap **(2)** with attached guy lines **(4)** onto the top of the assembled stack assembly.

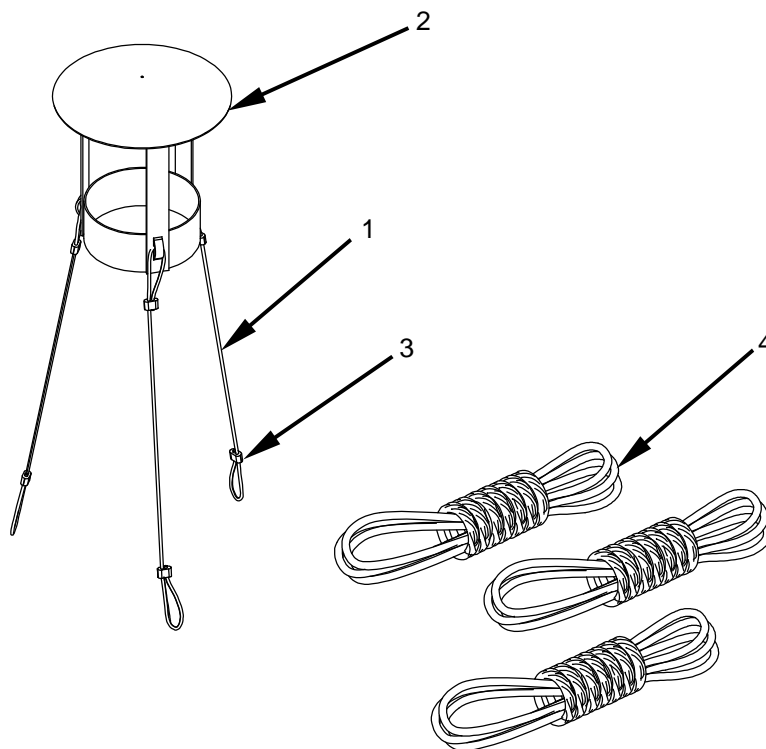
**END OF WORK PACKAGE**

SPACE HEATER SMALL (SHS)

NSN 4520-01-478-9207

OVERFLOW HOSE
REPLACE

INITIAL SETUP:

Tools

General Mechanics Tool Kit (WP 0029 00, Table 2, Item 1)

Personnel Required

One

Materials/Parts

Hose, rubber (WP 0044 00, Item 1)
Mat, petroleum absorbent (WP 0049 00, Item 8)

Equipment Condition

SHS shut-down and cool (WP 0005 00)

REPLACE

1. To replace the overflow hose **(1)**, squeeze the ends of the hose clamp **(2)** with pliers and slide the clamp back onto the overflow hose **(1)**. Have a petroleum absorbent mat or rag available to wipe up any fuel that may spill.
2. Pull the overflow hose **(1)** from the barb fitting **(3)**. Remove the hose clamp and set aside.
3. Slide the retained hose clamp **(2)** in position over the end of the new overflow hose **(1)**.
4. Install the new overflow hose **(1)** onto the barb fitting **(3)**.
5. Squeeze the hose clamp **(2)** ends with pliers and slide up and onto the end of the overflow hose **(1)**.

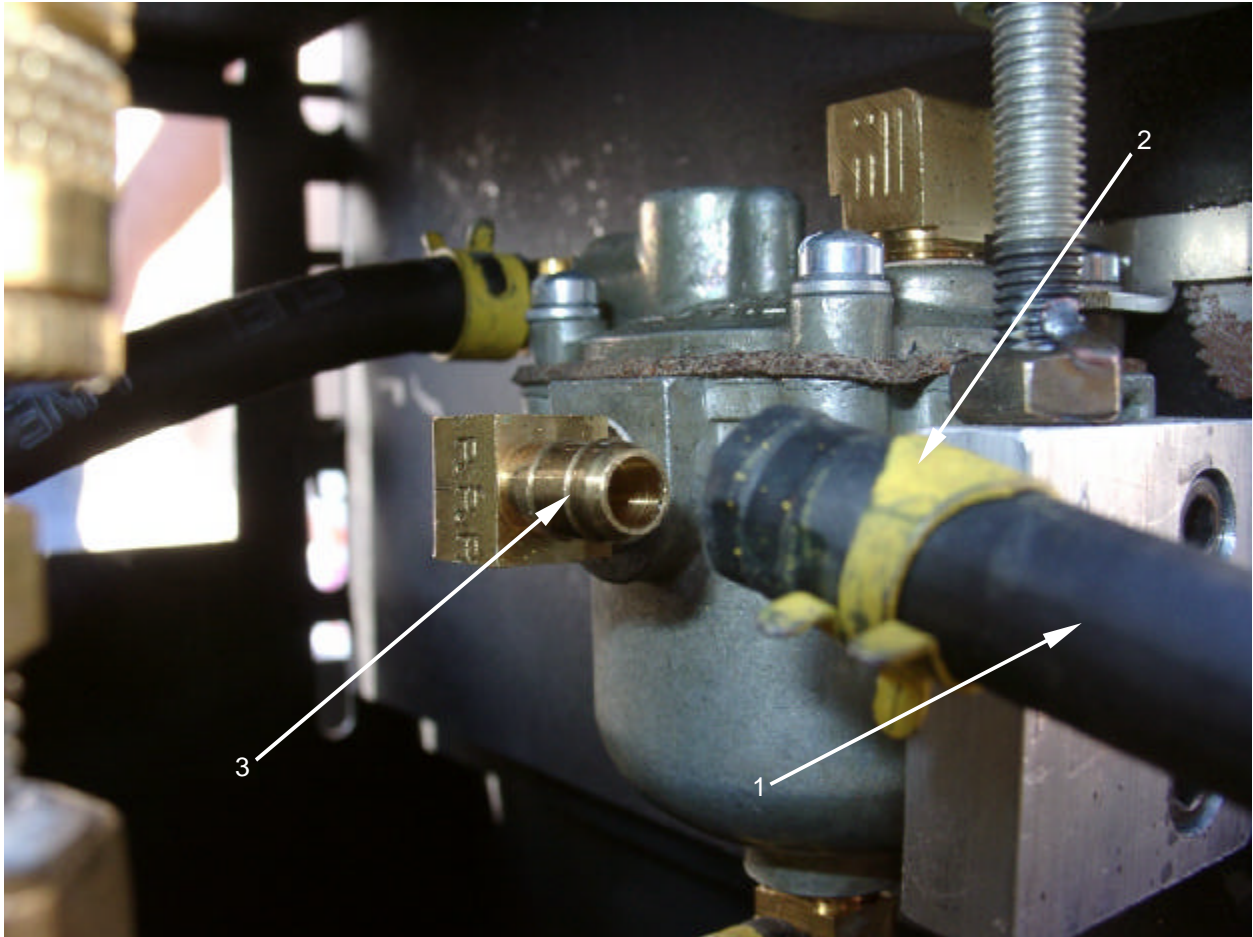

END OF WORK PACKAGE

SPACE HEATER SMALL (SHS)

NSN 4520-01-478-9207

FUEL TANK QD CONNECTOR
REPLACE

INITIAL SETUP:

Tools

General Mechanic Tool Kit
(WP 0029, Table 2, Item 1)

Materials/Parts

Rags, Wiping (WP 0049 00, Item 1)
Sealant, Thread (WP 0049 00, Item 7)
Mat, petroleum absorbent (WP 0049 00, Item 8)

Personnel Required

One

Equipment Condition

SHS shut-down and cool (WP 0005 00)
Drain fuel tank completely (WP 0018 00)

REPLACE

1. Be sure to drain all fuel from the fuel tank IAW WP 0018 00. Have a fuel petroleum mat and rag available to wipe up any spills that may occur.
2. Ensure that the fuel shut-off valve **(1)** on the heater is in the OFF position as shown on the fuel shut-off label.
3. Pull back the outer collar **(2)** of the fuel tank quick disconnect **(3)** and separate the fuel tank quick disconnect **(3)** from the male quick disconnect **(4)** mounted to the fuel shut-off valve **(1)**.
4. Loosen and remove the fuel tank QD connector **(1)** by unscrewing from the nipple **(5)** on the underside of the fuel tank **(6)**.
5. Wipe any thread sealant residue from the threads of the nipple **(5)**.
6. Apply new thread sealant to the threads of the nipple**(5)**.
7. Install the fuel QD connector **(1)** on the fuel tank nipple **(5)**. Tighten securely.
8. Pull back the outer collar **(2)** of the fuel tank quick disconnect **(3)** and reconnect to the male quick disconnect **(4)** on the fuel shut-off valve **(1)**.

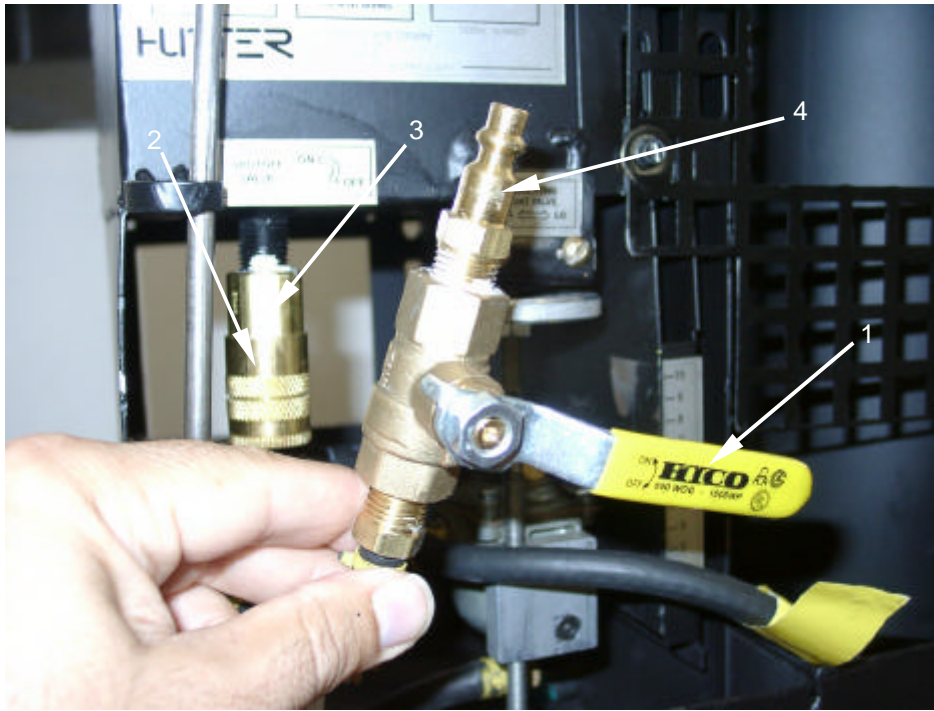

END OF WORK PACKAGE

SPACE HEATER SMALL (SHS)

NSN 4520-01-478-9207

REGULATING FLOAT VALVE
REPLACE

INITIAL SETUP:

Tools

General Mechanic Tool Kit
(WP 0029, Table 2, Item 1)

Materials/Parts

Mat, petroleum absorbent (WP 0049 00, Item 8)
Rags, Wiping (WP 0049 00, Item 1)

Personnel Required

One

Equipment Condition

SHS shut-down and cool (WP 0005)
Drain all fuel from heater (WP 0018 00)

REPLACE

1. Drain all fuel from fuel tank IAW WP 0018 00.
2. Remove regulating float valve assembly **(1)** by removing screws **(2)** and from heater body plate **(3)**. Swing the top of the regulating float valve to the left and pull the assembly with connected fuel hoses out from the heater interior.
3. Slide all hose clamps **(4)** back along the connecting hoses **(5)** and remove the hoses from the barbed fittings **(6)** on the regulating float valve assembly. Take note of the location of each hose so that they are reconnected properly.
4. Install all hoses **(5)** onto the barbed fittings **(6)** of the new regulating float valve assembly **(1)**. Be sure that the hoses are connected in the proper locations. Slide all hose clamps **(4)** up and over the barbed fittings. Ensure that the tabs on the hose clamps face up and are easily accessible once the regulating float valve is installed in the heater.
5. Install the new regulating float valve assembly **(1)** into the heater by engaging the bottom portion of the threaded shaft in the round retainer on the base of the heater. Swing the top of the regulating float valve assembly behind the heater body plate **(3)**. Ensure that the burner rate indicator arrow **(7)** is positioned snugly against the indicator scale **(8)**.
6. Install screws **(4)** in heater body plate **(5)** and secure.

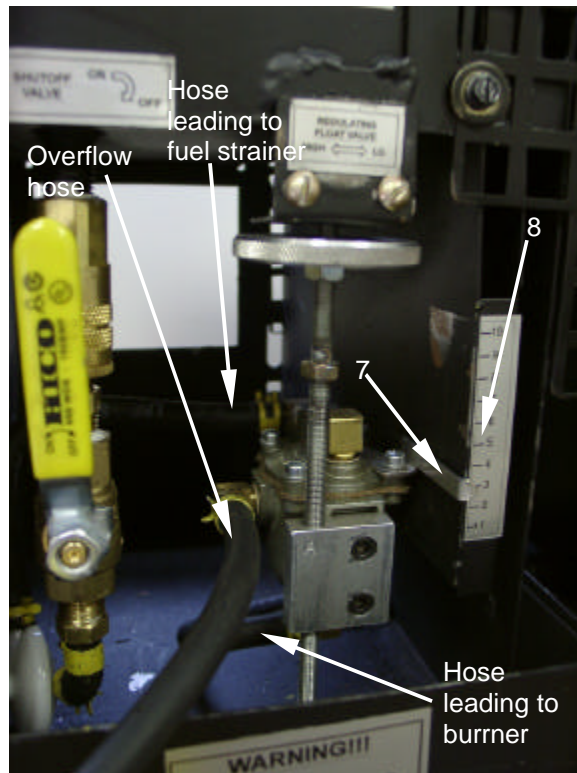
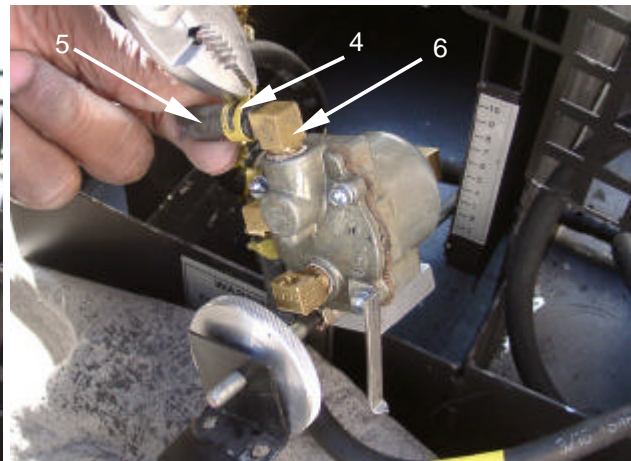
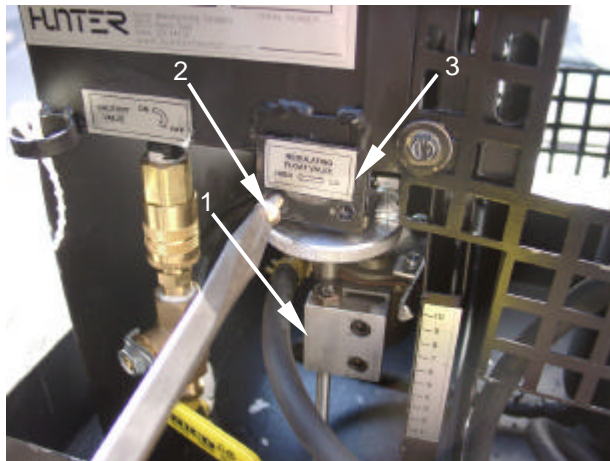

END OF WORK PACKAGE

SPACE HEATER SMALL (SHS)

NSN 4520-01-478-9207

FUEL STRAINER
REPLACE

INITIAL SETUP:

Tools

General Mechanic Tool Kit (WP 0029 00, Table 2, Item 1)

Personnel Required

One

Materials/Parts

Mat, Petroleum Absorbent (WP 0049 00, Item 8)
Rags, Wiping (WP 0049 00, Item 1)

Equipment Condition

SHS shut-down and cool (WP 0005 00)

REPLACE

1. To replace the fuel strainer **(1)**, move the lever on the fuel shut-off valve **(2)** to the OFF position. Disengage the fuel shut-off valve **(2)** from the fuel tank QD connector **(3)**. Have a petroleum absorbent mat and rag available to wipe up any spills that may occur. Pull the fuel shut-off valve out of the heater body to permit access to the fuel strainer **(1)**.
2. Observe the rear of the fuel strainer and note the fitting labeled "OUT" **(4)**. This fitting is connected to the fuel hose **(5)** leading to the regulating float valve assembly **(6)**.
3. Slide the hose clamps **(7)** on each fuel strainer fitting up onto the hoses **(8)** connected to the fuel strainer **(1)**.
4. Remove hoses **(8)** from the fittings on the fuel strainer **(1)**.
5. Remove fuel strainer assembly **(1)**.
6. Install a new fuel strainer **(1)** by installing the hoses **(8)** on the fittings. Note that the fitting labeled "OUT" **(4)** is connected to the hose **(5)** leading to the regulating float valve **(6)**.
7. Slide the hose clamps **(7)** up the hoses **(8)** and over the fuel strainer fittings.
8. Position the fuel shut-off valve assembly **(2)** inside the heater body taking care to align the handle so that it points toward the regulating float valve assembly **(6)**.
9. Engage the fuel QD connector **(3)** on the fuel tank with its mating half on the fuel shut-off valve **(2)**.

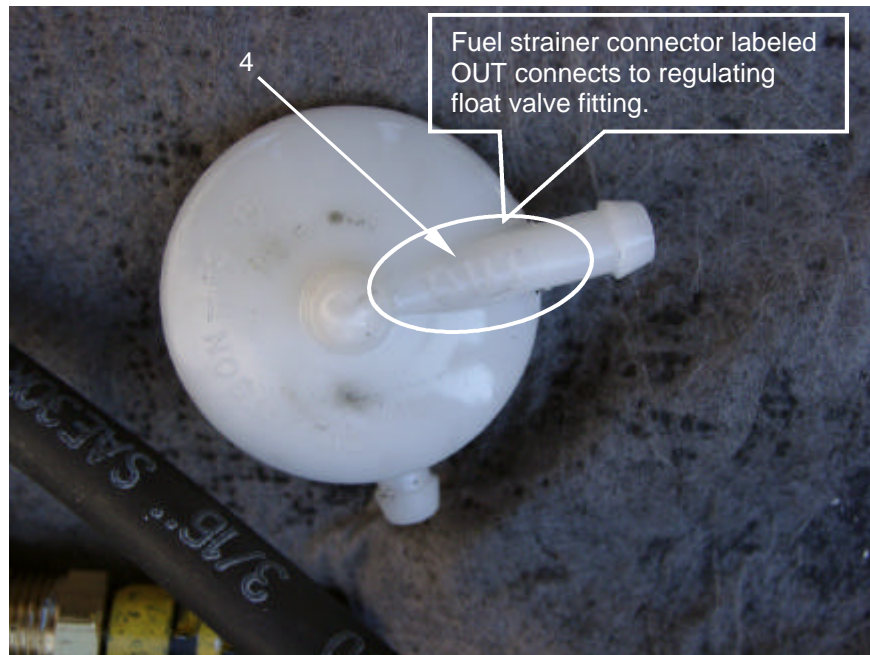
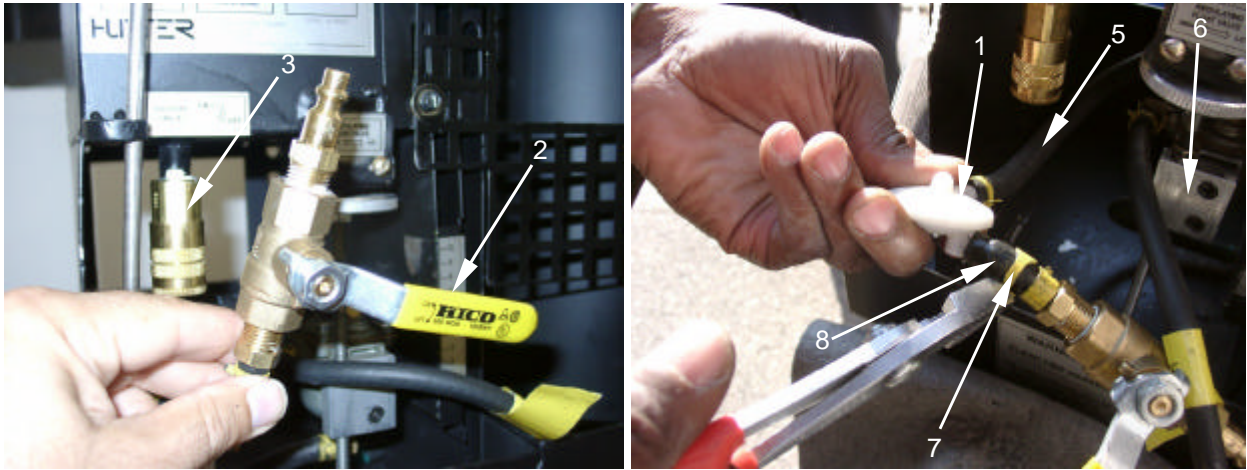

END OF WORK PACKAGE

SPACE HEATER SMALL (SHS)

NSN 4520-01-478-9207

FUEL SHUT-OFF VALVE ASSEMBLY
REPLACE

INITIAL SETUP:

Tools

General Mechanic Tool Kit
(WP 0029, Table 2, Item 1)

Personnel Required

One

Materials/Parts

Mat, petroleum absorbent (WP 0049 00, Table 1,
Item 8)

Rags, Wiping (WP 0049 00, Item 1)

Equipment Condition

SHS shut-down and cool (WP 0005)

REPLACE

1. To replace the fuel shut-off valve **(1)**, pull back the outer collar of the quick disconnect fitting **(2)** and disengage the two portions of the QD fitting. Have a fuel petroleum mat and rag available to wipe up any spills that may occur.
2. Squeeze the hose clamp **(3)** and slide down and over the fuel hose **(4)**.
3. Pull the fuel shut-off valve **(1)** off the fuel hose **(4)** with a twisting motion.
4. Install a new fuel shut-off valve **(1)** onto the fuel hose **(4)**.
5. Install the fuel hose clamp **(3)** by squeezing the clamp and sliding into position on the end of the hose **(4)**.
6. Engage the male portion of the quick disconnect fitting at the top of the fuel shut-off valve **(1)** to the fuel tank QD connector **(2)** on the underside of the fuel tank. Ensure that the handle **(5)** points to the regulating float valve assembly **(6)**.

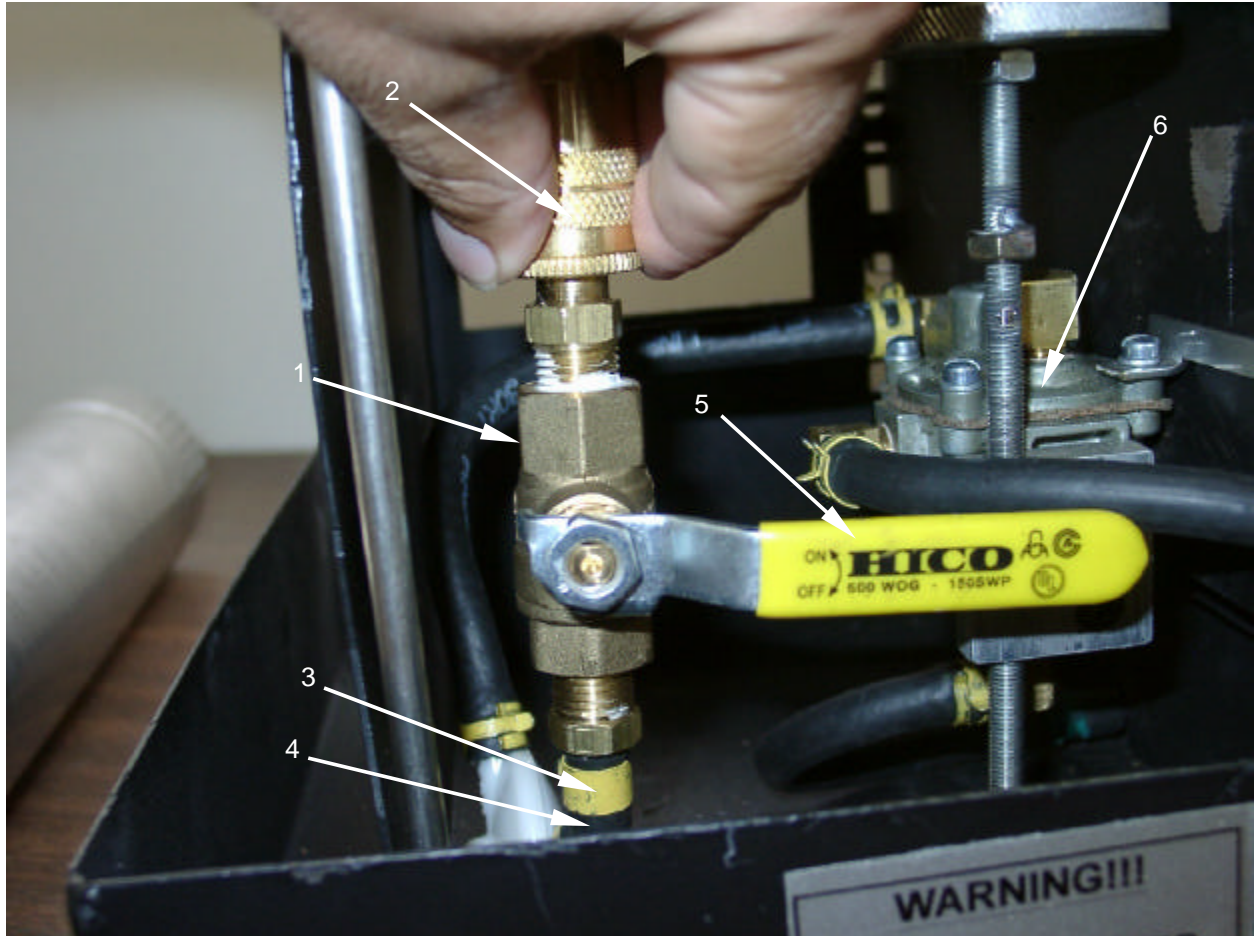

END OF WORK PACKAGE

SPACE HEATER SMALL (SHS)

NSN 4520-01-478-9207

HEAT SHIELD ASSEMBLY
REPLACE

INITIAL SETUP:

Tools

General Mechanic Tool Kit (WP 0029 00, Table 2, Item 1)

Personnel Required

One

Materials/Parts

Equipment Condition

SHS shut-down and cool (WP 0005 00)

REPLACE

1. To replace the heat shield **(1)**, remove the six screws and washers **(2)** that secure the heat shield **(1)** to the heater body **(3)**.
2. Remove the damaged heat shield **(1)**.
3. Install a new heat shield **(1)** in position on the heater body **(3)**. Align all screw holes **(4)** in the heat shield **(1)** with the holes **(5)** those in the heater body **(3)**.
4. Install all six screws and washers **(2)**.

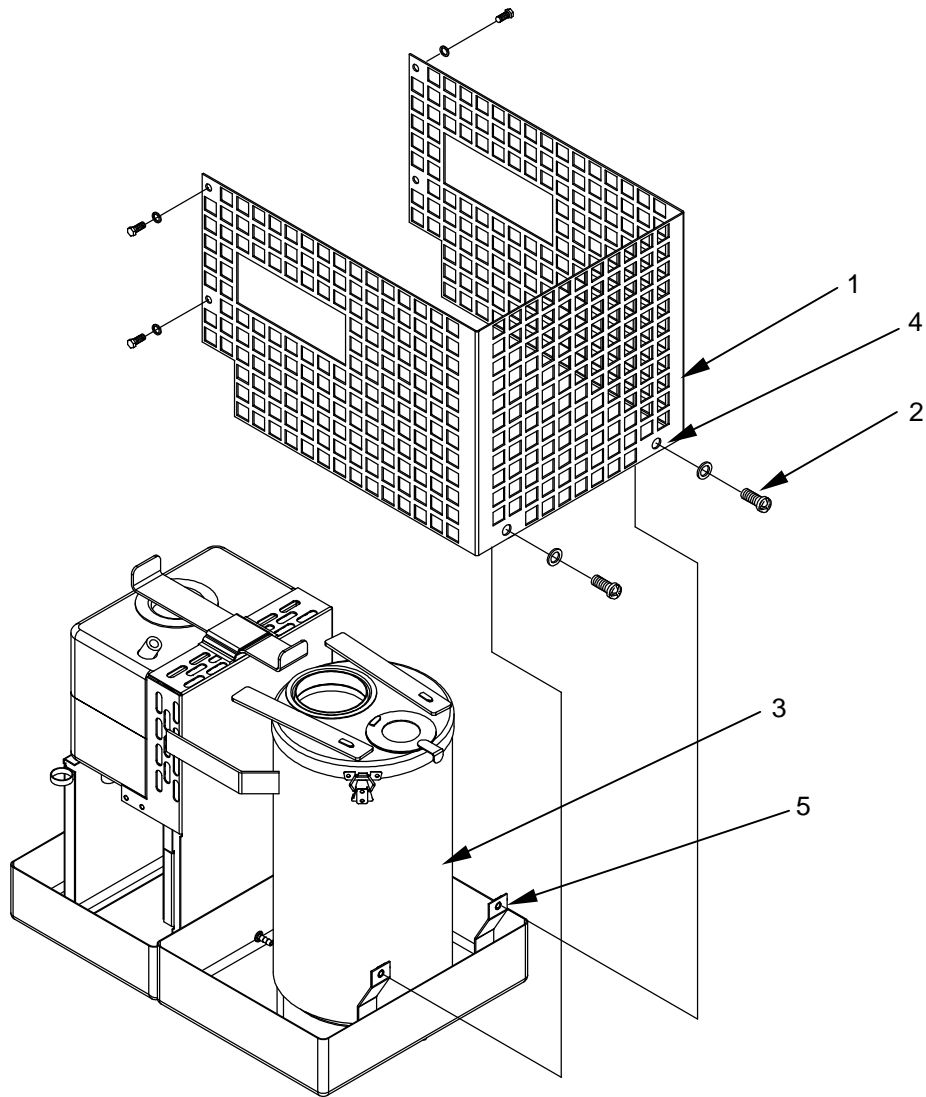

END OF WORK PACKAGE

TM 10-4520-263-12&P

CHAPTER 6
SUPPORTING INFORMATION
SPACE HEATER SMALL (SHS)

THIS PAGE INTENTIONALLY LEFT BLANK

**SPACE HEATER SMALL (SHS)
REFERENCES**

SCOPE

This section lists all field manuals, forms, technical manuals and miscellaneous publications referenced in this manual.

PAMPHLETS

Functional Users Manual for the
Army Maintenance Management System (TAMMS)DA PAM 738-750

FIELD MANUALS

Basic Cold Weather Manual FM 31-70
 First Aid for Soldiers FM 21-11
 NBC Decontamination FM 3-5
 Mountain Operations FM 3-97.6
 Northern Operations FM 31-71

FORMS

Discrepancy in Shipment Report SF 361
 Equipment Inspection and Maintenance Worksheet DA Form 2404
 Product Quality Deficiency Report SF 368
 Recommended Changes to Equipment Technical Publications DA Form 2028-2
 Report of Discrepancy SF 364
 Report of Packaging and Handling Deficiencies..... SF 362

TECHNICAL MANUALS

Destruction of Army Material to Prevent Enemy Use TM 750-244-2
 Administrative Storage of Equipment TM 740-90-1
 Preservation, Packaging, and Packing of Military Supplies and Equipment TM 38-230-2
 Five Soldier Crew Tent (FSCT) Type 1 and Type 2..... TM 10-8340-226-13&P
 Soldier Crew Tent (SCT) Type 1 and Type 2..... TM 10-8340-227-13&P

MISCELLANEOUS PUBLICATIONS

Army Medical Department Expendable/Durable Items..... CTA 8-100
 Expendable/Durable Items CTA 50-970

THIS PAGE INTENTIONALLY LEFT BLANK

**SPACE HEATER SMALL (SHS)
MAINTENANCE ALLOCATION CHART**

INTRODUCTION**The Army Maintenance System MAC**

This introduction provides a general explanation of all maintenance and repair functions authorized at various maintenance levels under the standard Army Maintenance System concept.

The MAC (immediately following the introduction) designates overall authority and responsibility for the performance of maintenance functions on the identified end item or component. The application of the maintenance functions to the end item or component shall be consistent with the capacities and capabilities of the designated maintenance levels, which are shown on the MAC in column (4) as:

Unit - includes two subcolumns, C (operator/crew) and O (unit) maintenance
Direct Support - includes an F subcolumn
General Support - includes an H subcolumn
Depot - includes a D subcolumn

The tools and test equipment requirements (immediately following the MAC) list the tools and test equipment (both special tools and common tool sets) required for each maintenance function as referenced from the MAC.

The remarks (immediately following the tools and test equipment requirements) contain supplemental instructions and explanatory notes for a particular maintenance function.

Maintenance Functions

Maintenance functions will be limited to and are defined as follows:

Inspect. To determine the serviceability of an item by comparing its physical, mechanical, and/or electrical characteristics with established standards through examination (e.g., by sight, sound, or feel.)

Test. To verify serviceability by measuring the mechanical, pneumatic, hydraulic, or electrical characteristics of an item and comparing those characteristics with prescribed standards

Service. Operations required periodically to keep an item in proper operating condition, i.e. to clean (includes decontaminate, when required), to preserve, to drain, to paint, or to replenish fuel, lubricants, chemical fluids, or gases.

Adjust. To maintain or regulate, within prescribed limits, by bringing into proper or exact position, or by setting the operating characteristics to specified parameters.

Align. To adjust specified variable elements of an item to bring about optimum performance.

Calibrate. To determine and cause corrections to be made, or to be adjusted on instruments, tests, measuring, and diagnostic equipment used in precision measurement. Consists of comparisons of two instruments, one of which is a certified standard of known accuracy, to detect and adjust any discrepancy in the accuracy of the instrument being compared.

Remove/Install. To remove and install the same item when required to perform service or other maintenance functions. Install may be the act of emplacing, seating, or fixing into position a spare, repair part, or module (component or assembly) in a manner to allow the proper function of equipment or system.

Replace. To remove an unserviceable item and install a serviceable counterpart in its place. **Replace** is authorized by the MAC and is shown as the 3rd position code of the SMR code.

Repair. The application of maintenance services, including fault location/troubleshooting, removal/installation, and disassembly/assembly procedures, and maintenance actions to identify troubles, and restore serviceability to an item by correcting specific damage, fault, malfunction, or failure in a part, subassembly, module (component or assembly), end item, or system.

NOTE!

The following definitions are applicable to the "repair" maintenance function:

Services - Inspect, test, service, adjust, align, calibrate, and/or replace.

Fault location/troubleshooting-The process of investigating and detecting the cause of equipment malfunctioning; the act of isolating a fault within a system or Unit Under Test (UUT).

Disassembly/assembly-The step by step breakdown (taking apart) of a spare/functional group coded item to the level of its least component, that is assigned an SMR code for the level of maintenance under consideration (i.e. identified as maintenance significant).

Actions-Welding, grinding, riveting, straightening, facing, machining, and or resurfacing.

Overhaul. That maintenance effort (service/action) prescribed to restore an item to a completely serviceable/operational condition as required by maintenance standards in appropriate technical publications (i.e., DMWR). Overhaul is normally the highest degree of maintenance performed by the Army. Overhaul does not normally return an item to like new condition.

Rebuild. Consists of those services/actions necessary for the restoration of unserviceable equipment to a like new condition in accordance with original manufacturing standards. Rebuild is the highest degree of material maintenance applied to Army equipment. The rebuild operation includes the act of returning to zero those age measurements (hours/miles, etc.) considered in classifying Army equipment/components.

Explanation of Columns in the MAC

Column 1, Group Number. Column 1 lists functional group code numbers, the purpose of which is to identify maintenance significant components, assemblies, subassemblies, and modules with the next higher assembly. End item group numbers are **A00**.

Column 2, Component/Assembly. Column 2 contains the names of components, assemblies, subassemblies, and modules for which maintenance is authorized.

Column 3, Maintenance Function. Column 3 lists the functions to be performed on the item listed in Column 2. (For detailed explanation, refer to the previous section entitled "Maintenance Functions")

Column 4, Maintenance Level. Column 4 specifies, by the listing of a work time figure (expressed as man-hours shown as whole hours or decimals) in the appropriate subcolumn(s), the level of maintenance authorized to perform the function listed in Column (3). This figure represents the active time required to perform that maintenance function at the indicated level of maintenance. If the number or the complexity of the tasks within the listed maintenance function vary at different maintenance levels, appropriate work time figures will be shown for each level. The work time figure represents the average time required to restore an item (assembly, subassembly, component, module, end item, or system) to a serviceable condition under typical field operating conditions. This time includes item preparation (including any necessary disassembly/assembly time), troubleshooting/fault location time, and quality assurance/quality control time in addition to the time required to perform the specific tasks identified for the maintenance functions authorized in the maintenance allocation chart. The system designations for the various maintenance levels are shown below:

- C Operator or crew
- F Direct Support Maintenance
- D Depot Maintenance
- O Unit Maintenance
- H General Support Maintenance

Column 5, Tools and Equipment. Column 5 specifies, by code, those common tool sets (not individual tools) common TMDE, and special tools, special TMDE, and support equipment required to perform the designated function.

Column 6, Remarks. This column, when applicable, contains a letter code, in alphabetic order, which is keyed to the remarks contained in Table 3.

Explanation of Columns in the Tools and Test Equipment Requirements

Column (1) - Tool or Test Equipment Reference Code. The tool or test equipment reference code correlates with a code used in column (5) of the MAC.

Column (2) - Maintenance Level. The lowest level of maintenance authorized to use the tool or test equipment.

Column (3) - Nomenclature. Name or identification of tool or test equipment.

Column (4) - National Stock Number (NSN). The NSN of the tool or test equipment.

Column (5) - Tool Number. The manufacturer's part number, model number, or type number.

Explanation of Columns in Remarks

Column (1) - Remarks Code. The code recorded in Column (6) of the MAC.

Column (2) - Remarks. This column lists information pertinent to the maintenance function being performed as indicated in the MAC.

Table 1. MAC for SPACE HEATER SMALL

(1) Group Number	(2) Component/Assembly	(3) Maintenance Function	(4) Maintenance Level					(5) Tools & Equip.	(6) Remarks
			Unit		Direct Support	General Support	Depot		
			C	O	F	H	D		
00	Space Heater Small	Inspect	0.2						
		Service		0.5				1	
		Repair		0.5				1	
01	Rain Cap Assembly	Replace		*				1	
		Inspect	0.5						
		Repair		0.5				1	
02	Stack Assembly	Replace		0.5					
		Inspect	0.5						
03	Canister Lid Assembly	Replace		0.1					
		Inspect	0.1						
04	Burner Shell and Downtube Assembly	Replace		0.1					
		Service		0.1				1	
05	Fuel Shut-off Valve	Replace		0.1					
		Inspect	0.1					1	
06	Overflow Hose	Replace		0.1					
		Inspect	0.1					1	
07	Regulating Float Valve	Replace		0.2					
		Inspect	0.1					1	
08	Fuel Tank QD Connector	Replace		0.1					
		Inspect	0.1					1	
09	Fuel Strainer Assembly	Replace		0.1					
		Inspect	0.1					1	
10	Heat Shield Assembly	Replace		0.1					
		Inspect	0.1					1	
11	Tent Collar Assembly	Replace		0.1					
		Inspect	0.1						
12	Label Kit	Replace		0.5					
		Inspect	0.1						

Table 2. Tools and Test Equipment for Space Heater Small

Tool or Test Equipment Ref Code	Maintenance Level	Nomenclature	National Stock Number	Tool Number
1	O	Tool Kit, General Mechanic's	5180-00-177-7033	SC 5180-90-CL-N26

Table 3. Remarks for SHS

REMARKS CODE	REMARKS
	N/A

THIS PAGE INTENTIONALLY LEFT BLANK

**SPACE HEATER SMALL (SHS)
REPAIR PARTS AND SPECIAL TOOLS LIST (RPSTL)**

SCOPE

This RPSTL lists and authorizes spare and repair parts; special tools; special tests, measurement and diagnostic equipment (TMDE); and other special support equipment required for performance of unit and direct support maintenance of the SHS. It authorizes the requisitioning, issue, and disposition of spares, repair parts, and special tools as indicated by the source, maintenance, and recoverability (SMR) codes.

GENERAL

In addition to this section, this RPSTL is divided into the following additional sections:

Repair Parts Sections. These sections contain lists of spares and repair parts authorized by this RPSTL for use in the performance of maintenance. These sections also include parts that must be removed for replacement of the authorized parts. Parts lists are composed of functional groups in ascending alphanumeric sequence, with the parts in each group listed in ascending figure and item number sequence. Hardware is listed with the components used. Bulk materials are listed by item name in FIG. BULK at the end of the sections. Repair parts kits are listed separately in their own functional group and section. Repair parts for reparable special tools are also listed in a separate section. Items listed are shown on the associated illustrations.

Special Tools List Sections. Sections containing lists of special tools, special TMDE, and special support equipment authorized by this RPSTL (as indicated by Basis of Issue (BOI) information in the DESCRIPTION AND USABLE ON CODE (UOC) column). Tools that are components of common tool sets and/or Class VII are not listed.

Cross-Reference Index Sections. There are two cross-reference indexes in this RPSTL; the National Stock Number (NSN) Index, and the Part Number Index. The NSN index refers you to the figure and the item number. The part number index also refers you to the figure and item number.

EXPLANATION OF COLUMNS IN THE RPSTL

ITEM NO. (Column (1)). Indicates the number used to identify items called out in the illustration.

SMR Code (Column (2)). The Source, maintenance, and recoverability (SMR) code is a 5-position code containing supply / requisitioning information, maintenance category authorization criteria and disposition instruction, as shown in the following breakout.

Source Code	Maintenance Code	Recoverability Code
X X	X	X
1st two positions:	3rd Position:	5th Position:
How you get an item	Who can install replace or use the item	Who determines disposition action on an item
	Who can do complete repair* on the item	

*Complete Repair: Maintenance capacity, capability, and authority to perform all corrective maintenance tasks of the Repair function in a use/user environment in order to restore serviceability to a failed item.

Source Code. The source code, tells you how to get an item needed for maintenance, repair, or overhaul of an end item/equipment. Explanation of source codes follows.

Source Code	Explanation
PA	Stock items; use the applicable NSN to request/requisition items with these source codes. They are authorized to the category indicated by the code entered in the third position of the SMR code.
PB	
PC**	
PD	
PE	
PF**	
PG	NOTE: Items coded PC are subject to deterioration.
KB	Items with these codes are not to be requested/requisitioned individually. They are part of a kit which is authorized to the maintenance category indicated in the 3rd position of the SMR code. The complete kit must be requisitioned and applied.
KD	
KF	
MO - Made at unit/AVUM Level	Items with these codes are not to be requested/requisitioned individually. They must be made from bulk material that is identified by the part number in the DESCRIPTION AND USABLE ON CODE (UOC) column and listed in the Bulk Material group of the repair parts list in this RPSTL. If the item is authorized to you by the 3rd position code of the SMR code, but the source code indicates it is made at a higher level, order the item from the higher level of maintenance.
MF- Made at DS/AVIM Level	
MH - Made at GS Level)	
ML - Made at Specialized Repair Act. (SRA)	
MD - Made at Depot	
AO - Assembled by Unit/AVUM Level	Items with these codes are not to be requested/requisitioned individually. The parts that make up the assembled item must be requisitioned or fabricated and assembled at the level of maintenance indicated by the source code. If the third position code of the SMR code authorizes you to replace the item, but the source code indicates the item is assembled at a higher level.
AF - Assembled by DS/AVIM Level	
AH - Assembled by GS level	
AL - Assembled by SRA order the item from the higher level of maintenance.	
AD - Assembled by Depot	
XA	Do not requisition an "XA" coded item. Order its next higher assembly. (Also, refer to the NOTE below.)
XB	If an "XB" item is not available from salvage, order it using the CAGEC and part number given.
XC	Installation drawing, diagram, instruction sheet, field service drawing, that is identified by manufacturer's part number.
XD	Item is not stocked. Order an "XD" coded item through normal supply channels using the CAGEC and part number given, if no NSN is available.



NOTE!

Cannibalization or controlled exchange, when authorized, may be used as a source of supply for items with the above source codes, except for those source coded "XA" or those aircraft support items restricted by requirements of AR 750-1.

Maintenance Code. Maintenance codes tell you the level(s) of maintenance authorized to use and repair support items. The maintenance codes are entered in the third and fourth positions of the SMR Code as follows:

Third Position. The maintenance code entered in the third position tells you the lowest maintenance level authorized to remove, replace, and use the support item. The maintenance code entered in the third position will indicate authorization to one of the following levels of maintenance.

Maintenance Code	Application/Explanation
C	Crew or operator maintenance done within unit/AVUM maintenance.
O	Unit level/AVUM maintenance can remove, replace, and use the item.
F	Direct support/AVIM maintenance can remove, replace, and use the item.
H	General support maintenance can remove, replace, and use the item.
L	Specialized repair activity can remove, replace, and use the item.
D	Depot level can remove, replace, and use the item.

Fourth Position. The maintenance code entered in the fourth position tells whether or not the item is to be repaired and identifies the lowest maintenance level with the capability to do complete repair (i.e., perform all authorized repair functions).



NOTE!

Some limited repair may be done on the item at a lower level of maintenance, if authorized by the Maintenance Allocation Chart (MAC) and SMR codes.

Maintenance Code	Application/Explanation
O	Unit/AVUM is the lowest level that can do complete repair of the item.
F	Direct support/AVIM is the lowest level that can do complete repair of the item.
H	General support is the lowest level that can do complete repair of the item.
L	Specialized repair activity (designate the specialized repair activity) is the lowest level that can do complete repair of the item.
D	Depot is the lowest level that can do complete repair of the item.
Z	Nonrepairable. No repair is authorized.
B	No repair is authorized. (No parts or special tools are authorized for the maintenance of a "B" coded item.) However, the item may be reconditioned by adjusting, lubricating, etc., at the user level.

Recoverability Code. Recoverability codes are assigned to items to indicate the disposition action on unserviceable items. The recoverability code is entered in the fifth position of the SMR Code as follows:

Code	Application/Explanation
Z	Nonrepairable item. When unserviceable, condemn and dispose of the item at the level of maintenance shown in 3rd position of SMR Code.
O	Repairable item. When uneconomically repairable, condemn and dispose of the item at organizational or aviation unit level.
F	Repairable item. When uneconomically repairable, condemn and dispose of the item at the direct support or aviation intermediate level.
H	Repairable item. When uneconomically repairable, condemn and dispose of the item at the general support level.
D	Repairable item. When beyond lower level repair capability, return to depot. Condemnation and disposal of item not authorized below depot level.
L	Repairable item. Condemnation and disposal not authorized below Specialized Repair Activity (SRA).
A	Item requires special handling or condemnation procedures because of specific reasons (e.g., precious metal content, high dollar value, critical material, or hazardous material). Refer to appropriate manuals/ directives for specific instructions.

NATIONAL STOCK NUMBER (NSN) (Column (3)). The NSN for the item is listed in this column.

CAGEC (Column (4)). The Commercial and Government Entity Code (CAGEC) is a 5-digit numeric code which is used to identify the manufacturer, distributor, or Government agency/activity that supplies the item.

PART NUMBER (Column (5)). Indicates the primary number used by the manufacture, (individual company, firm, corporation, or Government activity), which controls the design and characteristics of the item by means of its engineering drawings, specifications, standards, and inspection requirements to identify an item or range of items.



NOTE!

When an item with an assigned NSN is requisitioned, the part number for the item received may be different than the part number of the item being replaced.

DESCRIPTION AND USABLE ON CODE (UOC) (Column (6)). This column includes the following information:

The federal item name and, when required, a minimum description to identify the item.

Part numbers of bulk materials are referenced in this column in the line entry to be manufactured/fabricated.

Hardness Critical Item (HCI). A support item that provides the equipment with special protection from electromagnetic pulse (EMP) damage during a nuclear attack.

The statement "END of FIGURE@ appears just below the last item description in Column (5) for a given figure in both the repair parts list and special tools list.

QTY (Column 8). The QTY (quantity per figure) column indicates the quantity of the item used in the breakout shown on the illustration/figure, which is prepared for a functional group, subfunctional group, or an assembly. A "V" appearing in this column instead of quantity indicates that the quantity is a variable with each application.

EXPLANATION OF CROSS REFERENCE INDEX FORMAT AND COLUMNS

National Stock Number (NSN) Index

STOCK NUMBER Column. This column lists the NSN in national item identification number (NIIN) sequence. The NIIN consists of the last nine digits of the NSN, i.e.

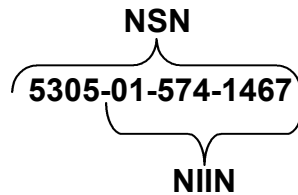

When using this column to locate an item, ignore the first four digits of the NSN. Use the complete NSN (13 digits) when requisitioning by stock number.

FIG. COLUMN. This column lists the number of the figure where the item is identified/located. The figures are in numerical order in Section II and Section III.

ITEM COLUMN. The Item number identifies the item associated with the figure listed in the adjacent FIG. Column. This item is also identified by the NSN listed on the same line.

PART NUMBER INDEX. Part numbers in this index are listed by part number in ascending alphanumeric sequence (i.e. vertical arrangement of letter and number combination which place the first letter or digit of each group in order A through Z, followed by the numbers 0 through 9, and each following letter or digit in like order).

CAGEC COLUMN. The Commercial and Government Entity Code (CAGEC) is a 5-digit numeric code used to identify the manufacturer, distributor, or Government agency/activity that supplies the item.

PART NUMBER COLUMN. Indicates the primary number used by the manufacturer (individual, firm, corporation, or government activity), which controls the design and characteristics of the item by means of its engineering drawings, specifications, standards and inspection requirements to identify an item or range of items.

STOCK NUMBER COLUMN. This column lists the NSN for the associated part number and manufacturer identified in the PART NUMBER and CAGEC columns to the left.

FIG. COLUMN. This column lists the number of the figure where the item is identified/located in the repair parts list and special tools list.

ITEM COLUMN. The item number is that number assigned to the item as it appears in the figure referenced in adjacent figure number column.

REFERENCE DESIGNATOR Column. Indicates the reference designator assigned to the item.

FIG. COLUMN. This column lists the number of the figure where the item is identified/located in the repair parts list and special tools list.

ITEM COLUMN. The item number is that number assigned to the item as it appears in the figure referenced in the adjacent figure number column.

STOCK NUMBER COLUMN. This column lists the NSN for the item.

CAGEC COLUMN. The Commercial and Government Entity Code (CAGEC) is a 5-digit numeric code used to identify the manufacturer, distributor, or Government agency/activity that supplies the item.

PART NUMBER COLUMN. Indicates the primary number used by the manufacturer (individual, firm, corporation, or Government activity), which controls the design and characteristics of the item by means of its engineering drawings, specifications, standards, and inspection requirements to identify an item or range of items.

SPECIAL INFORMATION.

USABLE ON CODE (UOC). The useable on code appears in the lower left corner of the Description Column heading. Useable on codes are shown as AUOC@ in the Description Column (justified left) on the first line under the applicable item description/nomenclature. Uncoded items are applicable to all models. Identification of the usable on codes used in this RPSTL are:

Equipment	Usable On Code
Space Heater Small	FSJ

FABRICATION INSTRUCTIONS. Bulk materials required to manufacture items are listed in the Bulk Material Functional Group of this RPSTL. Part numbers for bulk materials are also referenced in the description column of the line entry for the item to be manufactured/fabricated. Detailed fabrication instructions for items source coded to be manufactured or fabricated are found in TB 10-4500-200-13.

INDEX NUMBER. Items that have the word BULK in the figure column will have an index number shown in the item number column. This index number is a cross-reference between the National Stock Number/Part Number Index and the bulk material list in Section II.

ASSOCIATED PUBLICATIONS. The publications listed below pertain to the Space Heater Small and its components.

PUBLICATION

TM 10-4520-263-12&P

SHORT TITLE

Space Heater Small (SHS)

HOW TO LOCATE REPAIR PARTS.

When National Stock Numbers or Part Numbers are NOT known. First, using the table of contents, determine the assembly or subassembly group to which the item belongs. This is necessary since figures are prepared for assembly groups and subassembly groups, and listings are divided into the same groups.

Second, find the figure covering the assembly group or subassembly group to which the item belongs.

Third, identify the item on the figure and note the number(s).

Fourth, look in the repair parts list for the figure and item numbers. The NSNs and part numbers are on the same line as the associated item numbers.

When National Stock Number or Part Number IS known. First, if you have the NSN, look in the STOCK NUMBER column of the NSN index. The NSN is arranged in NIIN sequence. Note the figure and item number next to the NSN.

Second, turn to the figure and locate the item number. Verify that the item is the one you are looking for.

When Part Number is known. First, if you have the P/N and not the NSN, look in the PART NUMBER column of the P/N index. Identify the figure and item number.

Second, look up the item on the figure in the applicable repair parts list.

THIS PAGE INTENTIONALLY LEFT BLANK

THIS PAGE INTENTIONALLY LEFT BLANK

UNIT MAINTENANCE
SPACE HEATER, SMALL
(NSN 4520-01-478-9207)
RAIN CAP ASSEMBLY
REPAIR PARTS LIST

1
INCLUDES 2 THRU 4

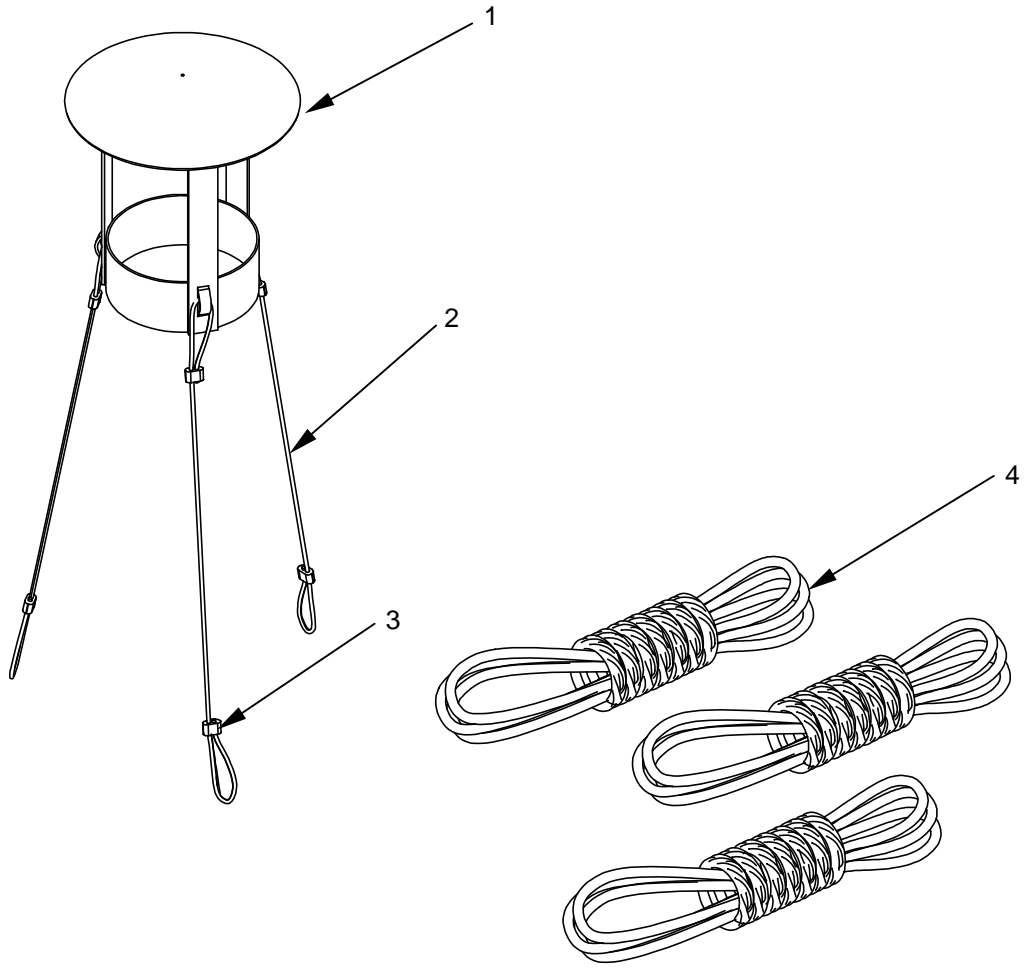

Figure 1. Group 01 Rain Cap Assembly

(1) ITEM NO.	(2) SMR CODE	(3) NSN	(4) CAGEC	(5) PART NUMBER	(6) DESCRIPTION AND USABLE ON CODE (UOC)	(7) QTY
					GROUP 01 RAIN CAP ASSEMBLY	
					FIG. 1 RAIN CAP ASSEMBLY	
1	PAOOO	4520-01-491-7563	92878	106447	RAIN CAP ASSY	1
2	XDOZZ		92878	MIL-W-83420	. ROPE, WIRE, TYPE I, 7 X 7 X 7/32 IN	V
3	XDOZZ		92878	MS51844-83	. SLEEVE, SWAGING	3
4	XDOZZ		92878	171218	. TENT LINE POLY PACK	1
					END OF FIGURE	

THIS PAGE INTENTIONALLY LEFT BLANK

THIS PAGE INTENTIONALLY LEFT BLANK

UNIT MAINTENANCE
SPACE HEATER, SMALL
(NSN 4520-01-478-9207)
STACK ASSEMBLY
REPAIR PARTS LIST

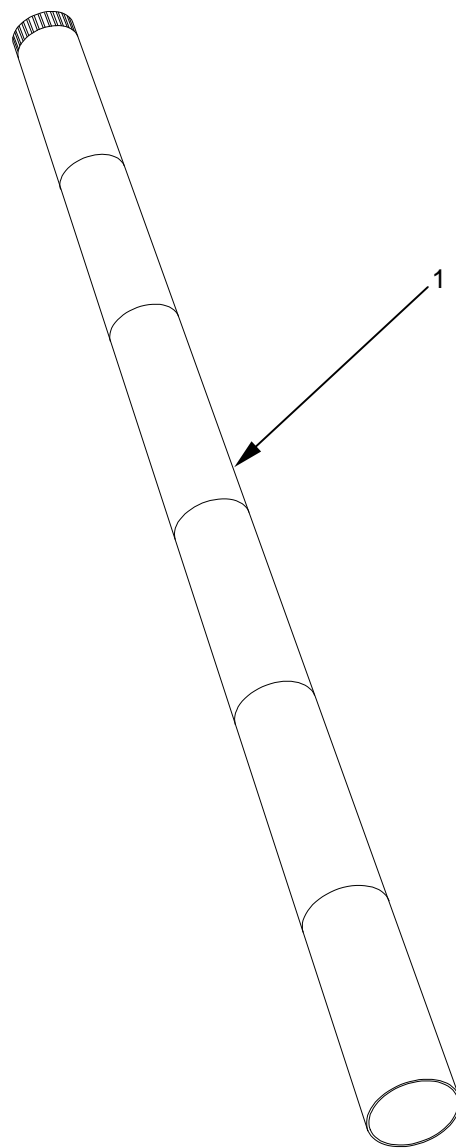

Figure 2. Group 02 Stack Assembly

(1) ITEM NO.	(2) SMR CODE	(3) NSN	(4) CAGEC	(5) PART NUMBER	(6) DESCRIPTION AND USABLE ON CODE (UOC)	(7) QTY
1	PAOZZ	4520-01-491-7569	92878	106444	GROUP 02 STACK ASSEMBLY FIG. 2 STACK ASSEMBLY STACK, PIPE END OF FIGURE	1

THIS PAGE INTENTIONALLY LEFT BLANK

THIS PAGE INTENTIONALLY LEFT BLANK

UNIT MAINTENANCE
SPACE HEATER, SMALL
(NSN 4520-01-478-9207)
CANISTER LID ASSEMBLY
REPAIR PARTS LIST

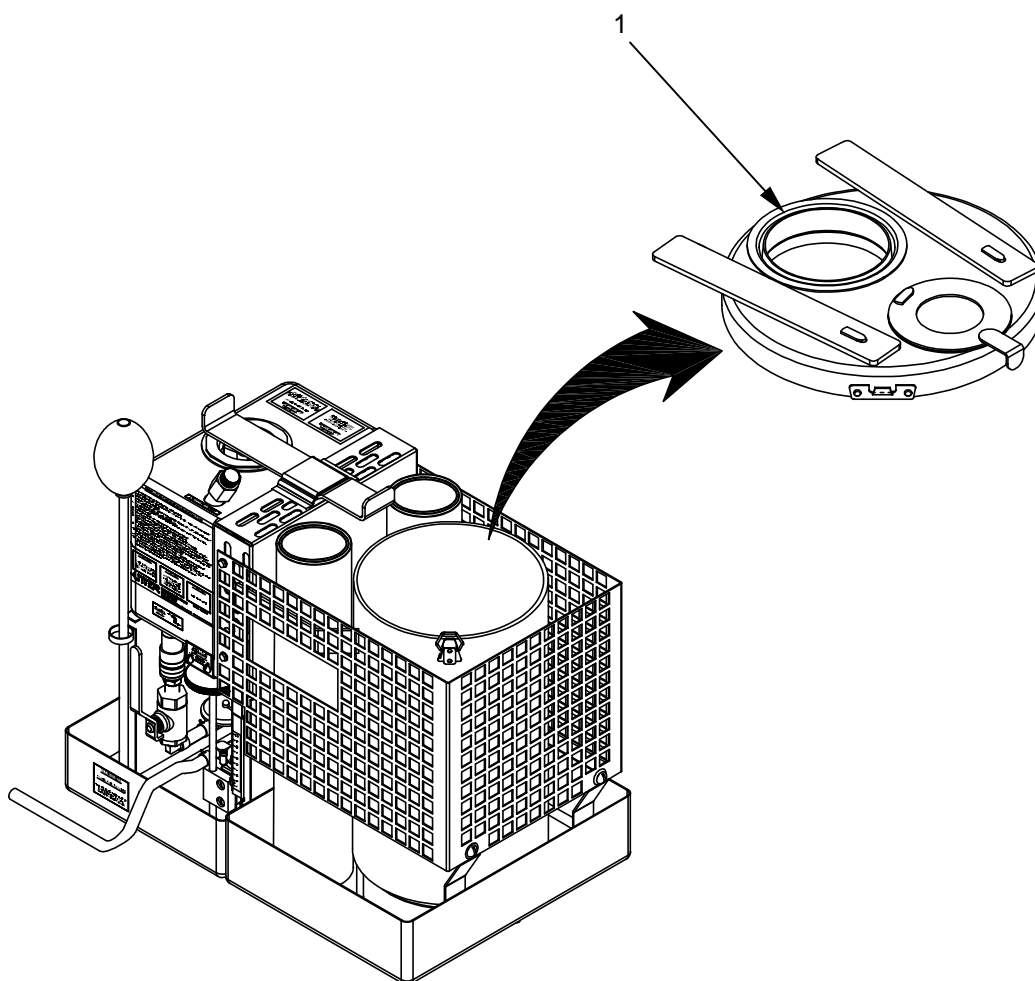

Figure 3. Group 03 Lid Assembly

(1) ITEM NO.	(2) SMR CODE	(3) NSN	(4) CAGEC	(5) PART NUMBER	(6) DESCRIPTION AND USABLE ON CODE (UOC)	(7) QTY
					GROUP 03 LID ASSEMBLY	
					FIG. 3 CANISTER LID ASSEMBLY	
1	PAOZZ	4520-01-491-7560	92878	106443	CANISTER LID ASSEMBLY	1
					END OF FIGURE	

THIS PAGE INTENTIONALLY LEFT BLANK

THIS PAGE INTENTIONALLY LEFT BLANK

UNIT MAINTENANCE
SPACE HEATER, SMALL
(NSN 4520-01-478-9207)
BURNER DOWNTUBE ASSEMBLY
REPAIR PARTS LIST

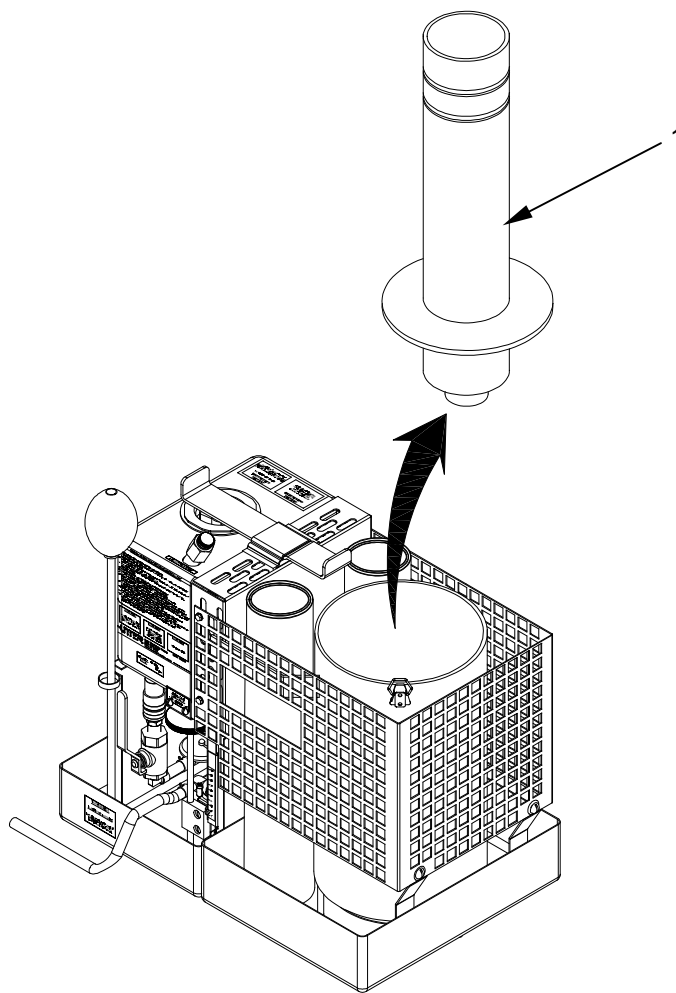

Figure 4. Group 04 Down Tube Assembly

(1) ITEM NO.	(2) SMR CODE	(3) NSN	(4) CAGEC	(5) PART NUMBER	(6) DESCRIPTION AND USABLE ON CODE (UOC)	(7) QTY
					GROUP 04 DOWN TUBE ASSEMBLY	
					FIG. 4 DOWN TUBE ASSEMBLY	
1	PAOZZ	4520-01-491-7273	92878	106428	BURNER S-TUBE ASSEMBLY	1
					END OF FIGURE	

THIS PAGE INTENTIONALLY LEFT BLANK

THIS PAGE INTENTIONALLY LEFT BLANK

UNIT MAINTENANCE
SPACE HEATER, SMALL
(NSN 4520-01-478-9207)
FUEL SHUT-OFF VALVE ASSEMBLY
REPAIR PARTS LIST

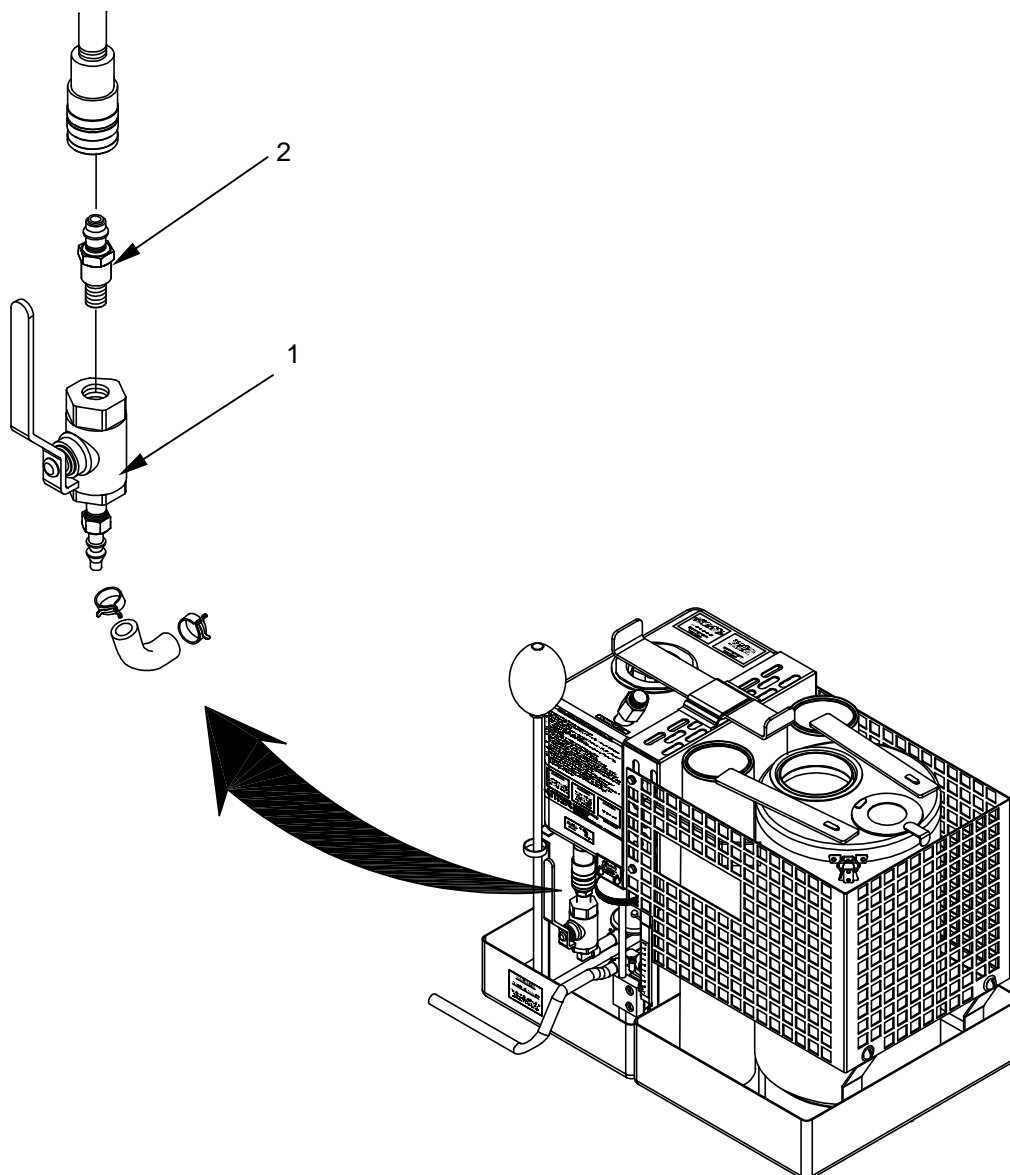

Figure 5. Group 05 Fuel Shut-off Valve Assembly

(1) ITEM NO.	(2) SMR CODE	(3) NSN	(4) CAGEC	(5) PART NUMBER	(6) DESCRIPTION AND USABLE ON CODE (UOC)	(7) QTY
					GROUP 05 FUEL SHUT-OFF VALVE ASSEMBLY	
					FIG. 5 FUEL SHUT-OFF VALVE ASSEMBLY	
1	PAOOZ	4520-01-491-7262	92878	106479	FUEL SHUT-OFF VALVE ASSEMBLY	1
2	PAOOZ		92878	106478	. MALE COUPLER	1
					END OF FIGURE	

THIS PAGE INTENTIONALLY LEFT BLANK

THIS PAGE INTENTIONALLY LEFT BLANK

UNIT MAINTENANCE
SPACE HEATER, SMALL
(NSN 4520-01-478-9207)
OVERFLOW HOSE
REPAIR PARTS LIST

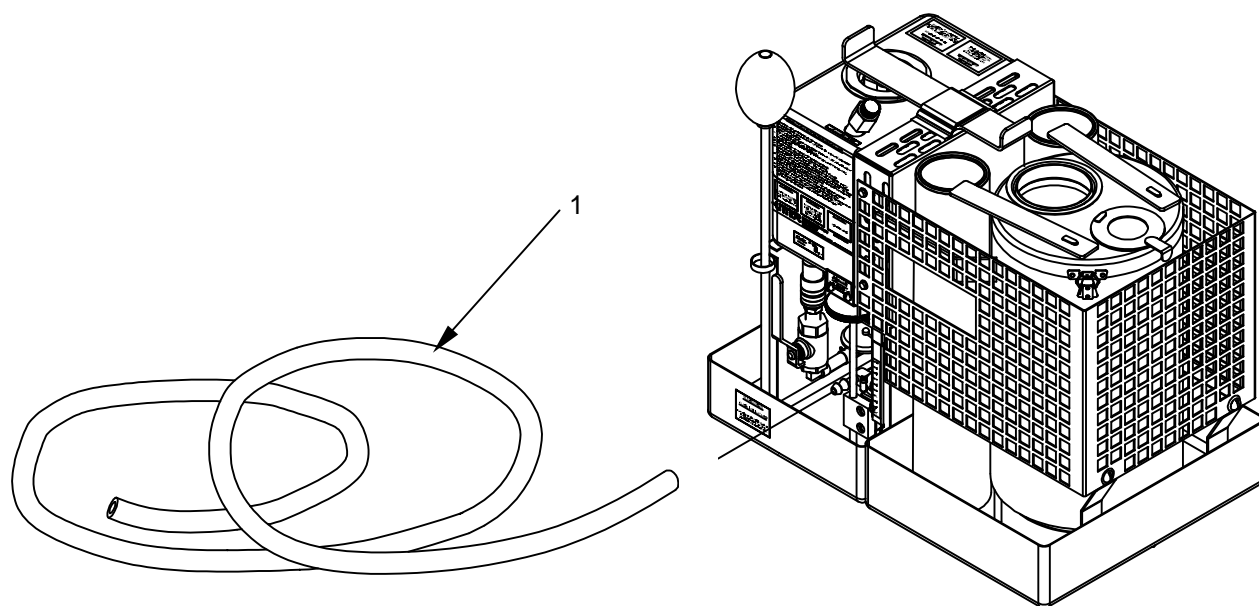

Figure 6. Group 6 Overflow Hose

(1) ITEM NO.	(2) SMR CODE	(3) NSN	(4) CAGEC	(5) PART NUMBER	(6) DESCRIPTION AND USABLE ON CODE (UOC)	(7) QTY
1	PAOZZ	4520-01-491-7276	92878	106475	GROUP 6 OVERFLOW HOSE FIG. 6 OVERFLOW HOSE HOSE, OVERFLOW END OF FIGURE	1

THIS PAGE INTENTIONALLY LEFT BLANK

THIS PAGE INTENTIONALLY LEFT BLANK

UNIT MAINTENANCE
SPACE HEATER, SMALL
(NSN 4520-01-478-9207)
REGULATING FLOAT VALVE ASSEMBLY
REPAIR PARTS LIST

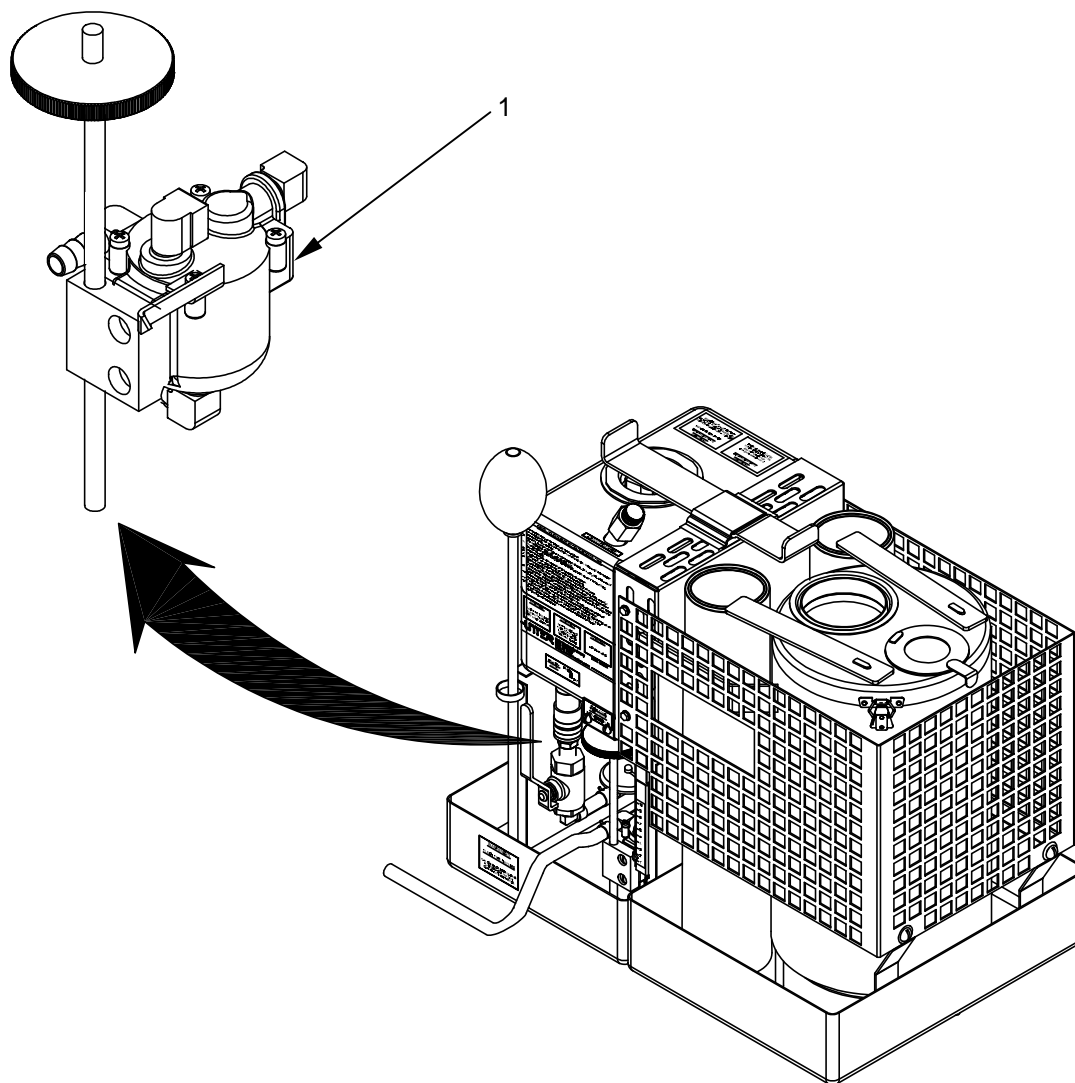

Figure 7. Group 07 Regulating Float Valve Assembly

(1) ITEM NO.	(2) SMR CODE	(3) NSN	(4) CAGEC	(5) PART NUMBER	(6) DESCRIPTION AND USABLE ON CODE (UOC)	(7) QTY
1	PAOZZ	4520-01-491-7258	92878	106464	GROUP 07 REGULATING FLOAT VALVE ASSEMBLY FIG. 7 REGULATING FLOAT VALVE ASSEMBLY REGULATING FLOAT VALVE ASSEMBLY END OF FIGURE	1

THIS PAGE INTENTIONALLY LEFT BLANK

THIS PAGE INTENTIONALLY LEFT BLANK

UNIT MAINTENANCE
SPACE HEATER, SMALL
(NSN 4520-01-478-9207)
FUEL TANK QD CONNECTOR
REPAIR PARTS LIST

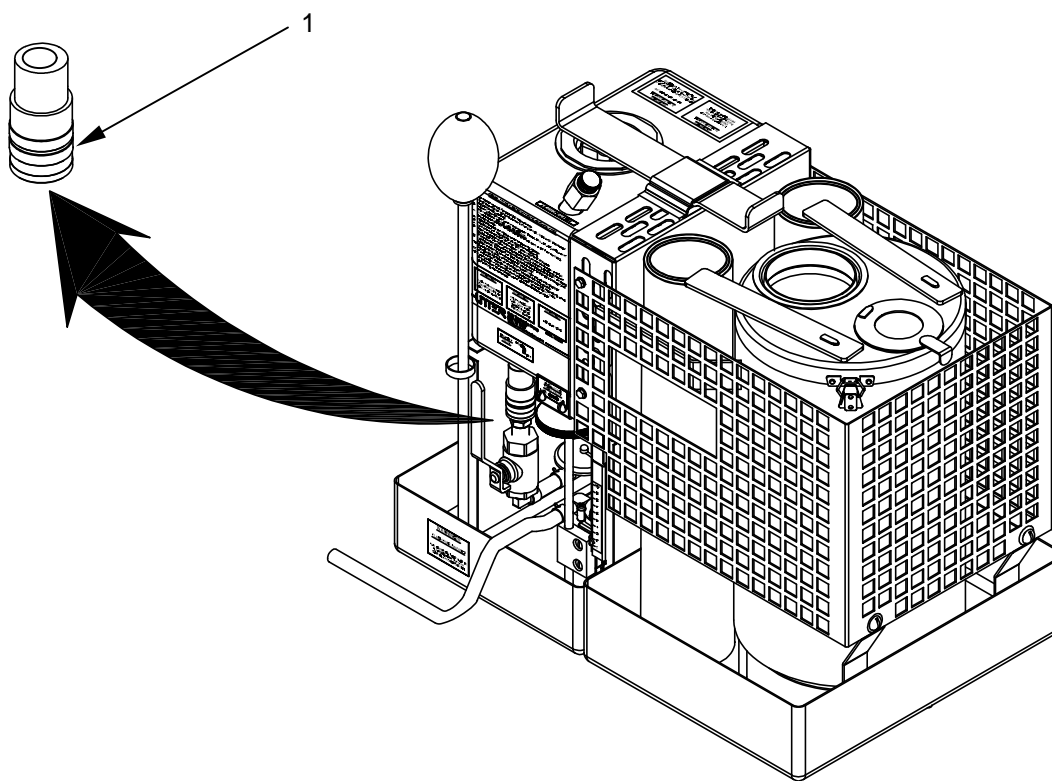

Figure 8. Group 08 Fuel Tank QD Connector

(1) ITEM NO.	(2) SMR CODE	(3) NSN	(4) CAGEC	(5) PART NUMBER	(6) DESCRIPTION AND USABLE ON CODE (UOC)	(7) QTY
1	PAOZZ	4520-01-491-7266	92878	106482	GROUP 08 FUEL TANK QD CONNECTOR FIG. 8 FUEL TANK QD CONNECTOR CONNECTOR, FEMALE END OF FIGURE	1

THIS PAGE INTENTIONALLY LEFT BLANK

THIS PAGE INTENTIONALLY LEFT BLANK

UNIT MAINTENANCE
SPACE HEATER, SMALL
(NSN 4520-01-478-9207)
FUEL STRAINER
REPAIR PARTS LIST

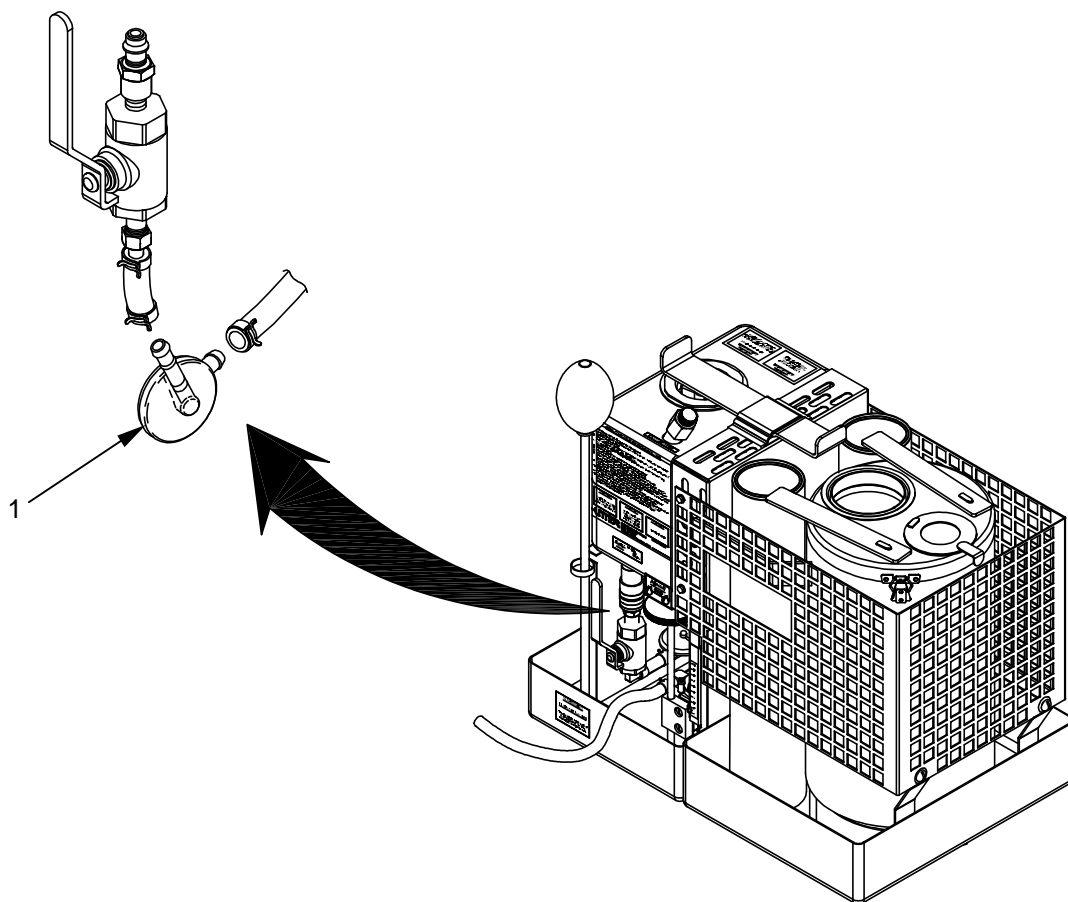

Figure 9. Group 09 Fuel Strainer

(1) ITEM NO.	(2) SMR CODE	(3) NSN	(4) CAGEC	(5) PART NUMBER	(6) DESCRIPTION AND USABLE ON CODE (UOC)	(7) QTY
					GROUP 09 FUEL STRAINER	
					FIG. 9 FUEL STRAINER	
1	PAOZZ	4520-01-491-7277	92878	106476	FUEL STRAINER	1
					END OF FIGURE	

THIS PAGE INTENTIONALLY LEFT BLANK

THIS PAGE INTENTIONALLY LEFT BLANK

UNIT MAINTENANCE
SPACE HEATER, SMALL
(NSN 4520-01-478-9207)
HEAT SHIELD ASSEMBLY
REPAIR PARTS LIST

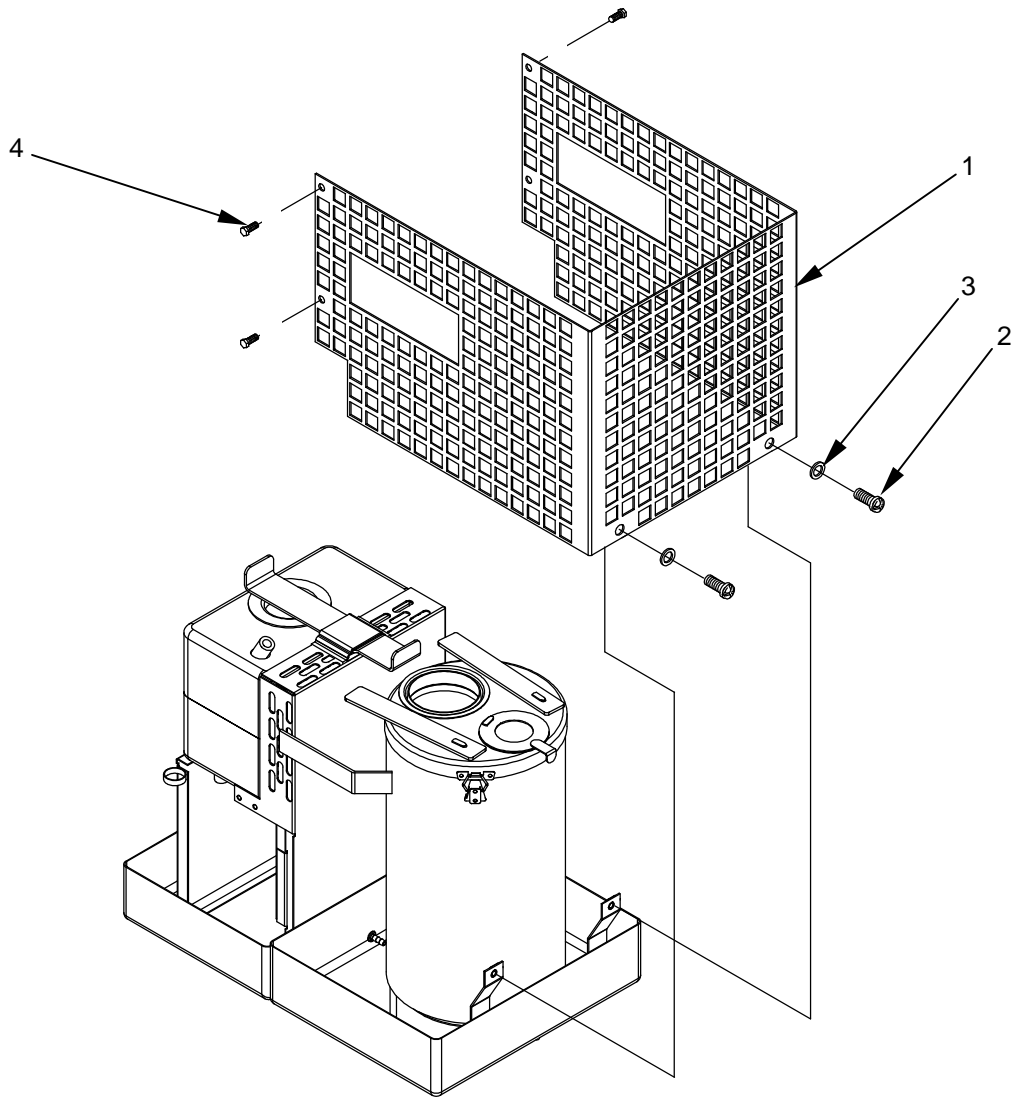

Figure 10. Group 10 Heat Shield Assembly
0040 00-(1 Blank)/2

(1) ITEM NO.	(2) SMR CODE	(3) NSN	(4) CAGEC	(5) PART NUMBER	(6) DESCRIPTION AND USABLE ON CODE (UOC)	(7) QTY
					GROUP 10 HEAT SHIELD ASSY	
					FIG. 10 HEAT SHIELD ASSY	
1	PAOZZ	4520-01-491-7561	92878	106528	HEAT SHIELD ASSEMBLY	1
2	XDOZZ		96906	MS35206-277	SCREW, 1/4-20X3/8	2
3	XDOZZ		96906	MS27183-10	WASHER, 9/32 FLAT	2
4	XDOZZ		92878	106481	SCREW, SELF TAP	4
					END OF FIGURE	

THIS PAGE INTENTIONALLY LEFT BLANK

THIS PAGE INTENTIONALLY LEFT BLANK

UNIT MAINTENANCE
SPACE HEATER, SMALL
(NSN 4520-01-478-9207)
TENT COLLAR ASSEMBLY
REPAIR PARTS LIST

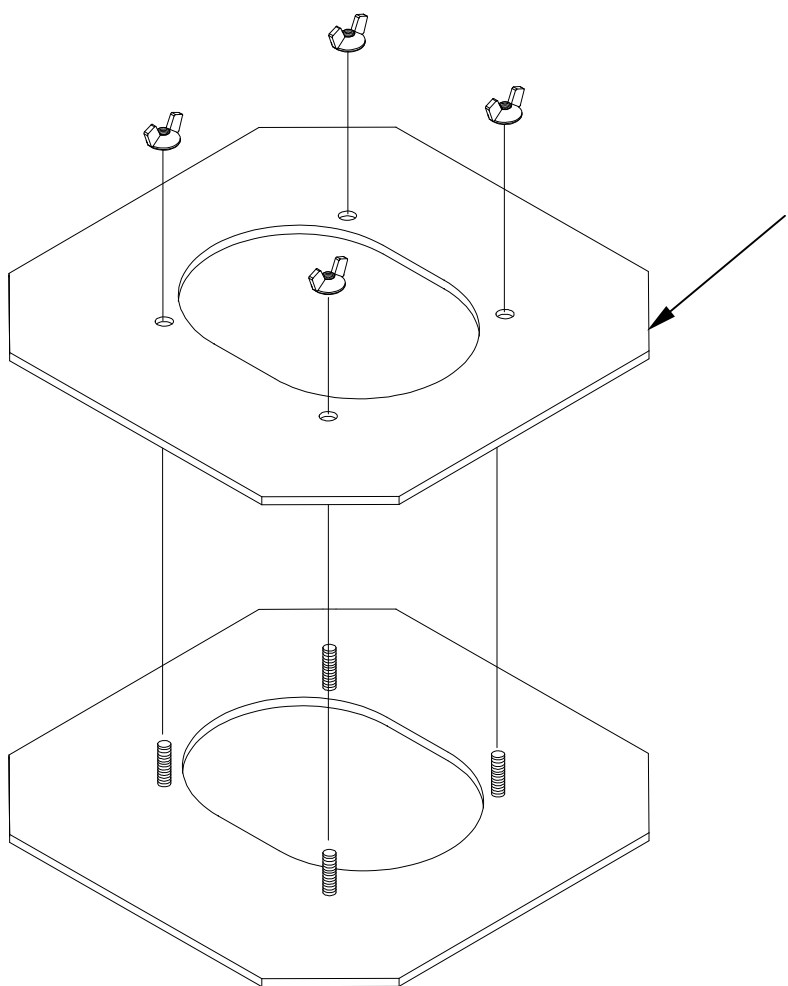

Figure 11. Group 11 Tent Collar Assembly

(1) ITEM NO.	(2) SMR CODE	(3) NSN	(4) CAGEC	(5) PART NUMBER	(6) DESCRIPTION AND USABLE ON CODE (UOC)	(7) QTY
					GROUP 11 TENT COLLAR ASSY	
					FIG. 11 TENT COLLAR ASSY	
1	PAOZZ	4520-01-491-7571	92878	106398	TENT COLLAR ASSEMBLY	1
2	XDOZZ		92878	106461	. NUT, WING	4
					END OF FIGURE	

THIS PAGE INTENTIONALLY LEFT BLANK

THIS PAGE INTENTIONALLY LEFT BLANK

UNIT MAINTENANCE
SPACE HEATER, SMALL
(NSN 4520-01-478-9207)

LABEL KIT

REPAIR PARTS LIST

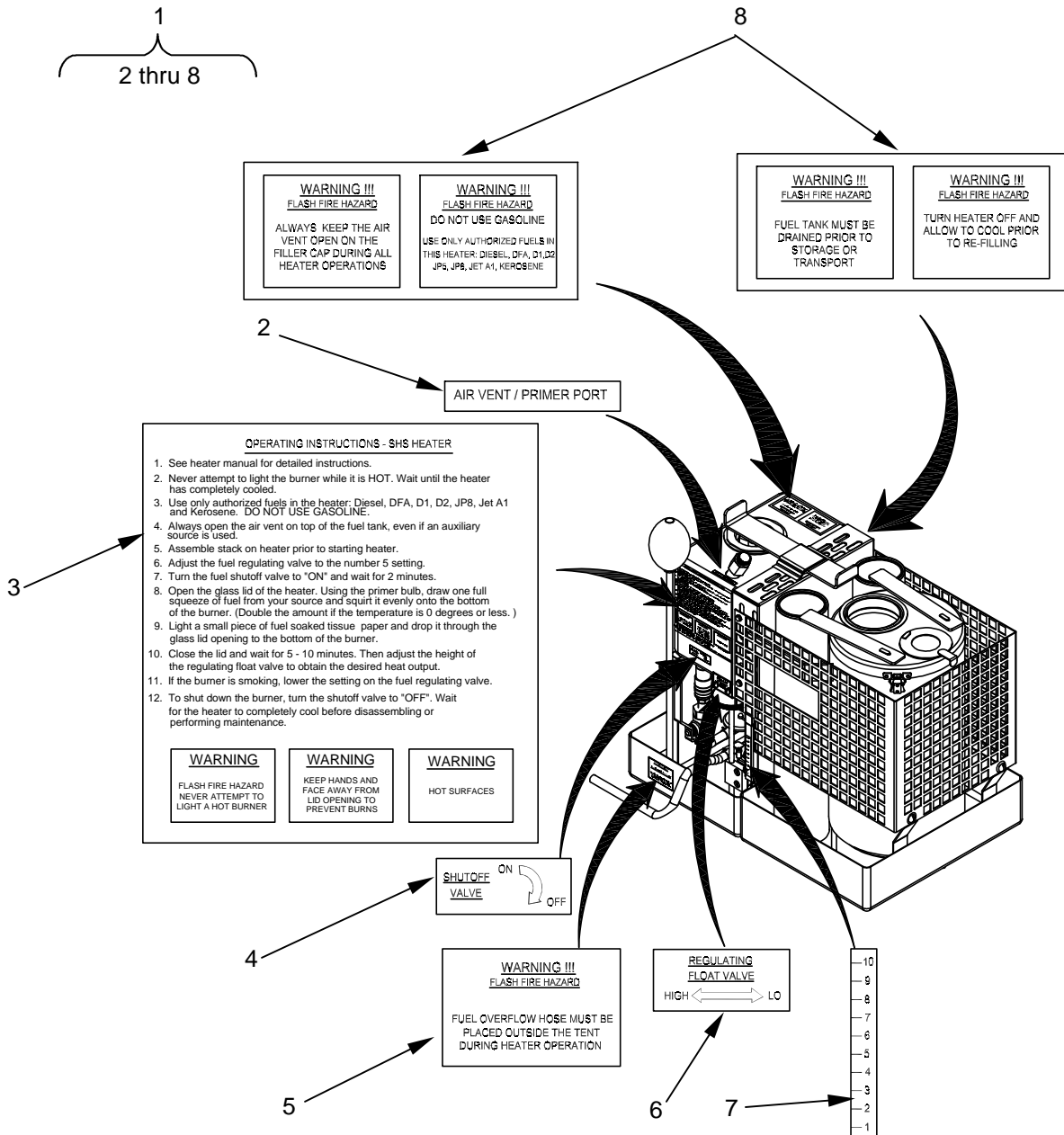

Figure 12. Group 12 Label Kit

(1) ITEM NO.	(2) SMR CODE	(3) NSN	(4) CAGEC	(5) PART NUMBER	(6) DESCRIPTION AND USABLE ON CODE (UOC)	(7) QTY
					GROUP 12 LABEL KIT	
					FIG. 12 LABEL KIT	
1	PAOZZ	4520-01-491-7573	92878	106530	KIT, LABEL	1
2	PAOZZ		92878	106521	. LABEL, PRIMER/VENT	1
3	PAOZZ		92878	106483	. LABEL, INSTRUCTION	1
4	PAOZZ		92878	106519	. LABEL, SHUT OFF	1
5	PAOZZ		92878	106520	. LABEL, FLOAT VALVE	1
6	PAOZZ		92878	106485	. LABEL, FUEL LEVEL	1
7	PAOZZ		92878	106518	. LABEL, OVERFLOW WARNING	1
8	PAOZZ		92878	106484	. LABEL, WARNING	1
					END OF FIGURE	

THIS PAGE INTENTIONALLY LEFT BLANK

THIS PAGE INTENTIONALLY LEFT BLANK

UNIT MAINTENANCE
SPACE HEATER, SMALL
(NSN 4520-01-478-9207)

FUEL CAP, PRIMER BULB, AIR VENT/PRIMER PORT CAP

REPAIR PARTS LIST

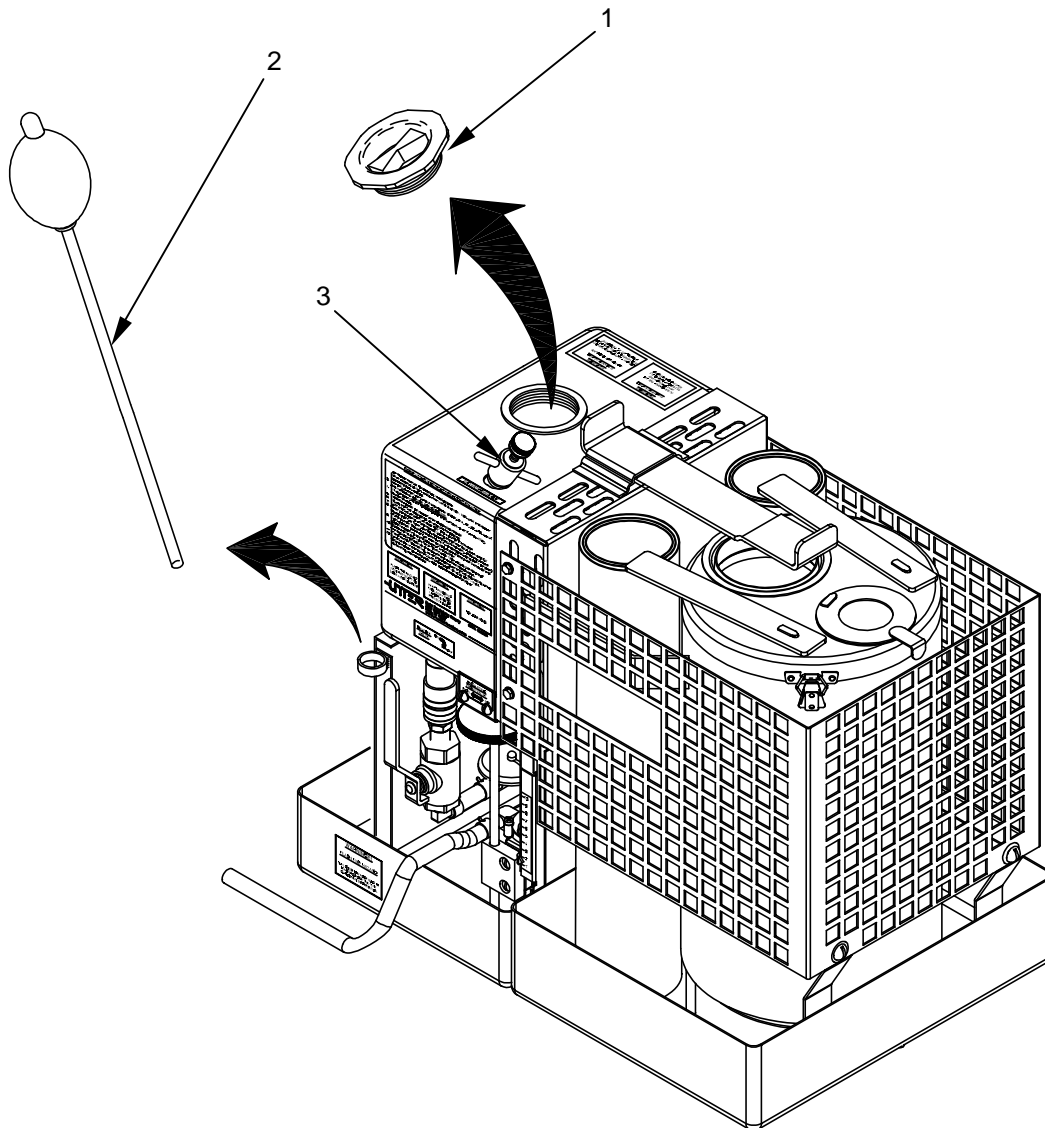

Figure 13. Group 13 Fuel Cap and Primer Bulb
0043 00-(1 Blank)/2

(1) ITEM NO.	(2) SMR CODE	(3) NSN	(4) CAGEC	(5) PART NUMBER	(6) DESCRIPTION AND USABLE ON CODE (UOC)	(7) QTY
					GROUP 13 FUEL CAP AND PRIMER BULB	
					FIG. 13 FUEL CAP AND PRIMER BULB	
1	PAOZZ	4520-01-491-7283	92878	106470	CAP, REPLACEMENT FUEL	1
2	PAOZZ	4520-01-491-7279	92878	106411	BULB, PRIMER	1
3	PAOZZ	4520-01-491-7281	92878	106524	CAP, AIR VENT/PRIMER PORT	1
					END OF FIGURE	

THIS PAGE INTENTIONALLY LEFT BLANK

**SPACE HEATER SMALL (SHS)
BULK MATERIAL REPAIR PARTS LIST**

(1) ITEM NO.	(2) SMR CODE	(3) NSN	(4) CAGEC	(5) PART NUMBER	(6) DESCRIPTION AND USABLE ON CODE (UOC)	(7) QTY
GROUP 9 BULK MATERIAL						
1	MOOZZ		99906	MIL-H-13444	HOSE, RUBBER, 1/4 IN. I.D.	AR
2	MOOZZ		96906	MIL-W-83420	WIRE ROPE 7 X 7 3/32	AR
END OF FIGURE						

THIS PAGE INTENTIONALLY LEFT BLANK

**SPACE HEATER SMALL (SHS)
NATIONAL STOCK NUMBER INDEX**

STOCK NUMBER	FIG.	ITEM
4520-01-491-7258	7	1
4520-01-491-7262	5	1
4520-01-491-7266	8	1
4520-01-491-7273	4	1
4520-01-491-7276	6	1
4520-01-491-7277	9	1
4520-01-491-7279	13	2
4520-01-491-7281	13	3
4520-01-491-7283	13	1
4520-01-491-7560	3	1
4520-01-491-7561	10	1
4520-01-491-7563	1	1
4520-01-491-7569	2	1
4520-01-491-7571	11	1
4520-01-491-7573	12	1

THIS PAGE INTENTIONALLY LEFT BLANK

**SPACE HEATER SMALL (SHS)
PART NUMBER INDEX**

PART NUMBER	FIG.	ITEM
MIL-W-83420	1	2
MIL-W-83420	14	2
MIL-H-13444	14	1
MS35206-277	10	2
MS51844-83	1	3
MS27183-10	10	3
106398	11	1
106411	13	2
106428	4	1
106443	3	1
106444	2	1
106447	1	1
106461	11	2
106464	7	1
106470	13	1
106475	6	1
106476	9	1
106478	5	2
106479	5	1
106481	10	4
106482	8	1
106483	12	3
106484	12	8
106485	12	6
106518	12	7
106519	12	4
106520	12	5
106521	12	2
106524	13	3
106528	10	1
106530	12	1
171218	1	4

THIS PAGE INTENTIONALLY LEFT BLANK

**SPACE HEATER SMALL (SHS)
COMPONENTS OF END ITEM (COEI) AND BASIC ISSUE ITEMS (BII) LIST**

INTRODUCTION**Scope**

This section lists COEI and BII for the SHS to help you inventory items for safe and efficient operation of the equipment.

General

The COEI and BII information is divided into the following lists:

Components of End Item (COEI). This list is for information purposes only and is not authority to requisition replacements. These items are part of the SHS. As part of the end item, these must be with the end item whenever it is issued or transferred between property accounts. Items of COEI are removed and separately packaged for transportation or shipment only when necessary. Illustrations are furnished to help you find and identify the items.

Basic Issue Items (BII). These essential items are required to place the SHS in operation, operate it, and to do emergency repairs. Although shipped separately packaged, BII must be with the SHS during operation and when it is transferred between property accounts. Listing these items is your authority to request / requisition them for replacement based on authorization of the end item by the TOE/MTOE. Illustrations are furnished to help you find and identify the items.

Explanation of Columns in the COEI List and BII List

Column 1, Illus Number, gives you the number of the item illustrated.

Column 2, National Stock Number, identifies the stock number of the item to be used for requisitioning purposes.

Column 3, Description, CAGEC, and Part Number, identifies the Federal item name (in all capital letters) followed by a minimum description when needed. The last line below the description is the CAGEC (commercial and Government entity code) (in parenthesis) and the part number.

Column 4, Usable on code, gives you a code if the item you need is not the same for different models of equipment. There is no usable on code for the Space Heater Small.

Column 5, UM (unit of measure), indicates how the item is issued for the National Stock Number shown in column 2.

Column 6, Qty Rqr, indicates the quantity required.

COMPONENTS OF END ITEM (COEI) LIST

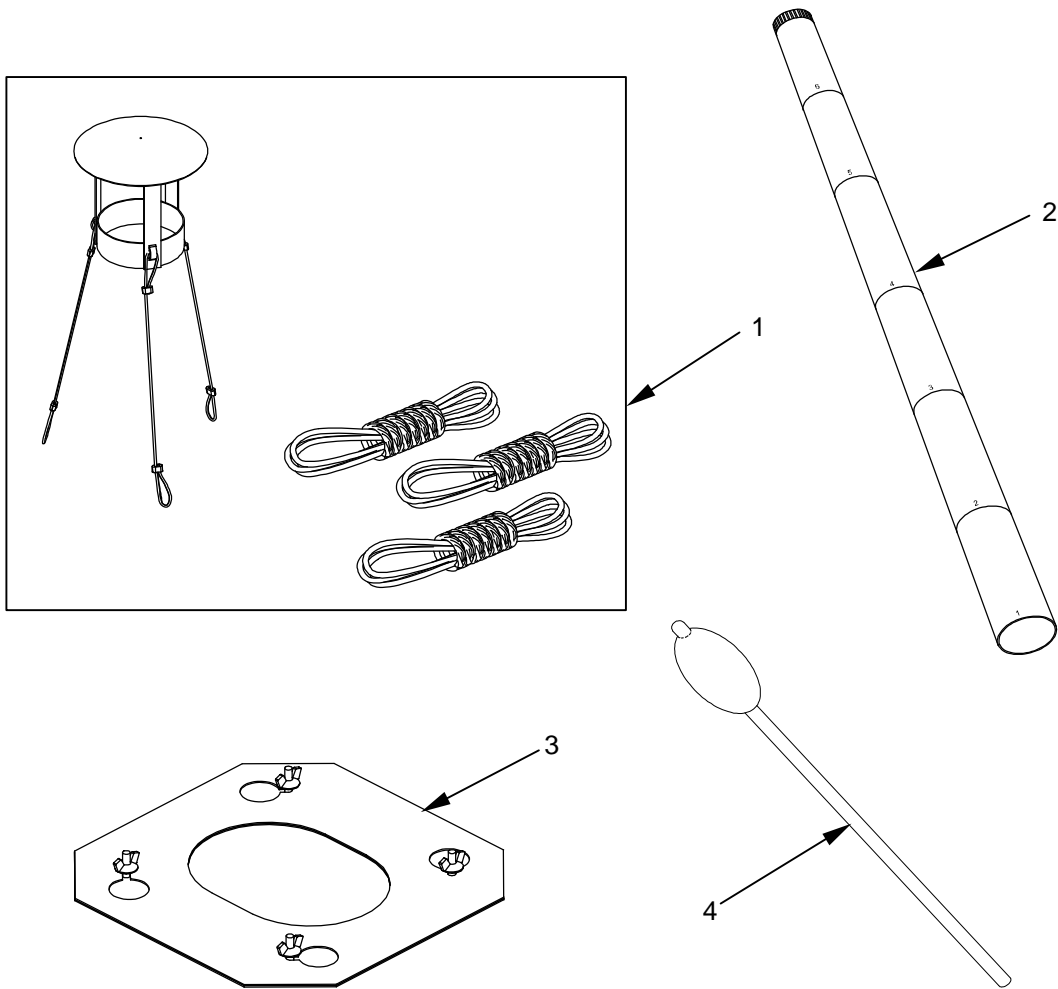
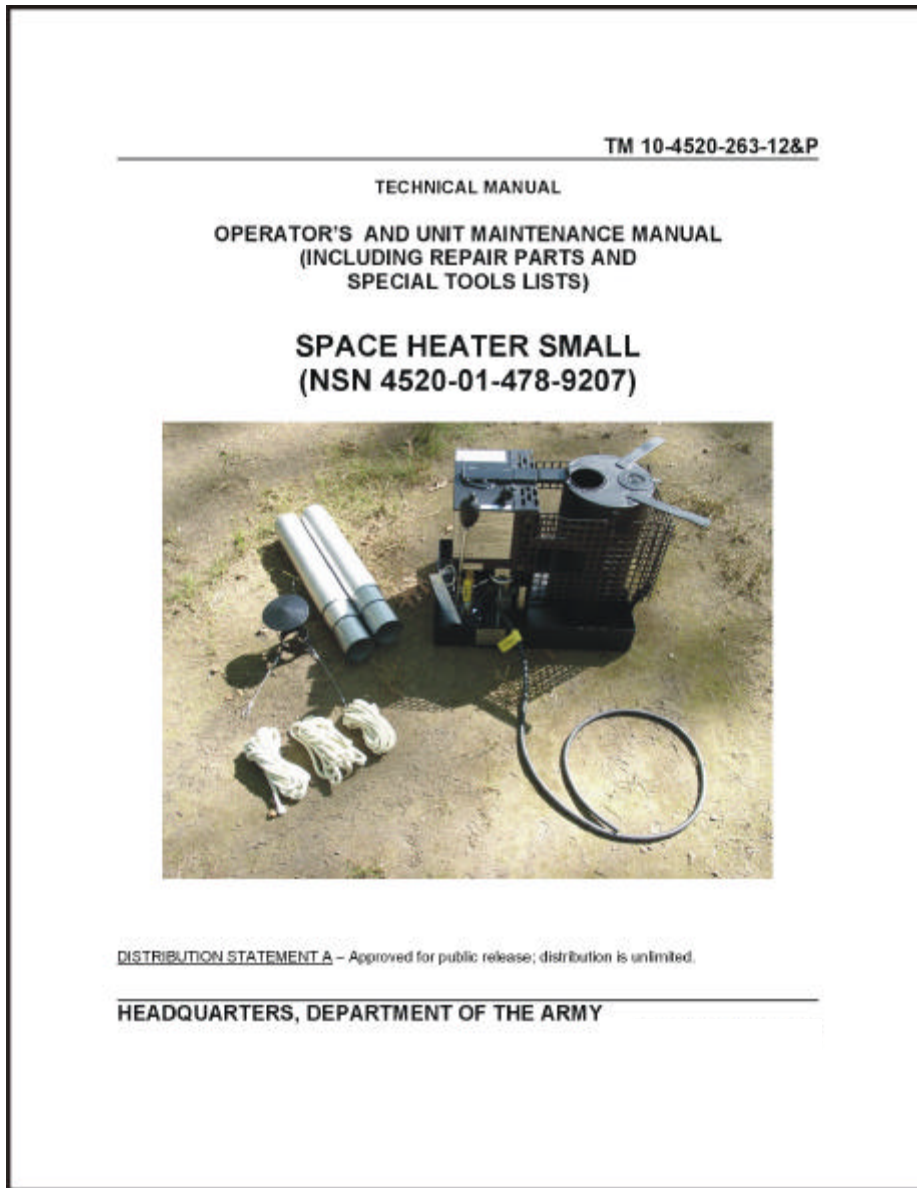

Table 1. Components of End Item List.

(1) ILLUS NUMBER	(2) NATIONAL STOCK NUMBER	(3) DESCRIPTION, LOCATION, PART NUMBER, AND (CAGEC)	(4) USABLE ON CODE	(5) U/M	(6) QTY RQR
1		RAIN CAP ASSEMBLY 106447 (92878)	CVF	EA	1
2		STACK ASSEMBLY 106444 (92878)	CVF	EA	1
3		TENT COLLAR ASSEMBLY 106398 (92878)	CVF	EA	1
4		PRIMING BULB 106411 (92878)	CVF	EA	1

BASIC ISSUE ITEMS (BII) LIST



1

Table 2. Basic Issue Items List

(1) ILLUS NUMBER	(2) NATIONAL STOCK NUMBER	(3) DESCRIPTION, PART NUMBER AND CAGEC	(4) USABLE ON CODE	(5) U/M	(6) QTY RQR
1	N/A	TM 10-4520-263-12&P		EA	1

THIS PAGE INTENTIONALLY LEFT BLANK

**SPACE HEATER SMALL (SHS)
ADDITIONAL AUTHORIZATION LIST (AAL)**

INTRODUCTION

Scope

This section lists additional items you are authorized for the support of the SHS.

General

This list identifies items that do not have to accompany the SHS and that do not have to be turned in with it. These items are all authorized to you by CTA, MTOE, TDA, or JTA.

Explanation of Columns in the AAL:

Column (1) National Stock Number, identifies the stock number of the item to be used for requisitioning purposes.

Column (2) Description, CAGEC, and Part Number, identifies the Federal Item Name (in all capital letters) followed by a minimum description when needed. The last line below the description is the CAGE (Commercial and Government Entity Code) (in parenthesis) and the part number.

Column (3), Usable On Code, when applicable, gives you a code if the item you need is not the same for different models of equipment.

Column (4), UM (unit of measure) indicates how the item is issued for the National Stock Number shown in column (1).

Column (5), Qty Recm, indicates the quantity recommended.

ADDITIONAL AUTHORIZED LIST ITEMS

Table 1. Additional Authorization List.

(1) NATIONAL STOCK NUMBER	(2) DESCRIPTION, (CAGEC) AND PART NUMBER	(3) USABLE ON CODE	(4) U/M	(5) QTY RECM
7240-01-337-5268	CAN (DT), FUEL, MILITARY (81349) MIL-C-53109	FSJ	EA	1
7240-01-337-5269	CAN (CG), FUEL, MILITARY (81349) MIL-C-53109	FSJ	EA	1
4520-01-466-0420	FUEL HOSE WITH PRIMING CUP (92878) 106367	FSJ	EA	1
4520-01-465-4430	FUEL CAN STAND, COLLAPSIBLE (92878) 106369	FSJ	EA	1
4520-01-466-0415	GRAVITY FEED ADAPTER (92878) 171230	FSJ	EA	1
7240-00-177-6154	SPOUT, CAN, FLEX (81349) MIL-S-1285	FSJ	EA	1
8415-00-227-1220	GLOVES, MEN'S AND WOMEN'S, SMALL (81349) MIL-G-10902	FSJ	PR	1
8415-00-227-1221	GLOVES, MEN'S AND WOMEN'S, MEDIUM (81349) MIL-G-10902	FSJ	PR	1
8415-00-227-1222	GLOVES, MEN'S AND WOMEN'S, LARGE (81349) MIL-G-10902	FSJ	PR	1

THIS PAGE INTENTIONALLY LEFT BLANK

**SPACE HEATER SMALL (SHS)
EXPENDABLE AND DURABLE ITEMS LIST**

INTRODUCTION

Scope

This section lists expendable and durable items that you will need to operate and maintain the SHS. This list is for information only and is not authority to requisition the listed items. These items are authorized to you by CTA 50-970, Expendable/Durable Items (Except Medical, Class V Repair Parts, and Heraldic Items), or CTA 8-100, Army Medical Department Expendable/Durable Items.

Explanations of Columns in the Expendable / Durable Items List

Column (1) Item Number. This number is assigned to the entry in the list and is referenced in the narrative instructions to identify the item (e.g., Use lubricating oil (WP0046, Table 1, Item 1).

Column (2) Level. This column includes the lowest level of maintenance that requires the listed item.

- C** Operator or Crew
- O** Unit Maintenance
- F** Direct Support Maintenance
- H** General Support Maintenance
- D** Depot Maintenance

Column (3) National Stock Number. This is the NSN assigned to the item which you can use to requisition it.

Column (4) Item Name, Description, CAGEC, and Part Number. This column provides the other information you need to identify the item.

Column (5), U/M (unit of measure) indicates how the item is issued for the National Stock Number shown in column (1).

EXPENDABLE AND DURABLE ITEMS LIST

Table 1. Expendable and Durable Items List.

(1) ITEM NUMBER	(2) LEVEL	(3) NATIONAL STOCK NUMBER	(4) ITEM NAME, DESCRIPTION, (CAGEC), PART NUMBER	(5) U/M
1	C,O	7920-00-205-3570	WIPING RAGS	LB
2	C,O		ALCOHOL, ISOPROPYL, TT-I-735	GL
3	C,O		CLAMP, HOSE (SIZE 06) (81349) SAE-J-I508,TYPE M	EA
4	C,O	4010-00-222-4474	ROPE, WIRE (81349) MIL-W-83420 TYPE I	FT
5	C,O		SLEEVE, SWAGING (81349) MS51844-83	BX
6	C,O		ROPE, NYLON (92878) 171218	FT
7	C,O		SEALANT, THREAD, 5-13-5357, (81337)	OZ
8	C,O	7930-01-363-8631	MAT, PETROLEUM ABSORBENT, GOV106 (1JA49)	RL
9	C,O	9920-00-174-3194	MATCHES, SAFETY, PAPER (96906) A-A-59489 TYPE 1 CLASS A	EA

THIS PAGE INTENTIONALLY LEFT BLANK

**SPACE HEATER SMALL (SHS)
MANDATORY REPLACEMENT PARTS LIST**

INTRODUCTION**Scope**

This work package includes a list of all mandatory replacement parts referenced in the task initial setups and procedures. These are items that must be replaced during maintenance whether they have failed or not. This includes items based on usage intervals such as miles, time, rounds fired, etc.

MANDATORY REPLACEMENT PARTS LIST

There are no mandatory replacement parts for the Space Heater Small.

THIS PAGE INTENTIONALLY LEFT BLANK

**SPACE HEATER SMALL (SHS)
ALPHABETICAL INDEX**

ALPHABETICAL INDEX

A

Abbreviations and Acronyms0001 00
 Additional Authorization List (AAL)0048 00
 Army Maintenance System MAC.....0029 00
 Assembly And Preparation For Use0005 00

B

Basic Issue Items (BI) List0047 00
 Bulk Material Repair Parts List0044 00

C

Cleaning0013 00
 Common Tools And Equipment.....0002 00
 Components Of End Item (COEI) List0047 00
 Controls And Indicators0004 00
 Corrosion Prevention And Control (CPC).....0001 00

D

Decals And Instruction Plates.....0004 00
 Description and Use of Operator's Controls and Indicators0004 00
 Destruction Of Army Materiel To Prevent Enemy Use0001 00
 Description Of System Components0002 00

E

Environmental Limits on Equipment0002 00
 Equipment Characteristics, Capabilities And Features0001 00
 Equipment Data0002 00
 Equipment Improvements and Recommendations, Reporting (EIR)0001 00
 Expendable and Durable Items List.....0049 00
 Explanation of Columns in the MAC.....0029 00
 Explanation of Columns in the Tools and Test Equipment Requirements0029 00
 Explanation of Columns in Remarks0029 00

F

Field Manuals0028 00
 Forms0028 00

G

General Information0001 00

H

How to Locate Repair Parts0030 00
 How to Use this Manual iv

I

Introduction To Components Of End Item (COEI) and Basic Issue Items (BII) List.....0047 00
 Introduction To Maintenance Allocation Chart0029 00

L

List Of Abbreviations/Acronyms0001 00
 Location And Description Of Major Components0002 00
 Lubrication Service Intervals0010 00

M

Maintenance Allocation Chart For SHS System.....0029 00
 Maintenance Forms Records And Reports0028 00
 Maintenance Functions0029 00
 Maintenance, Direct Support0029 00
 Maintenance Procedures, Unit0019 00
 Malfunction Symptom Index0008 00
 Mandatory Replacement Parts0050 00

N

National Stock Number Index.....0045 00
 Nomenclature Cross-Reference List0001 00

O

Operations under Usual Conditions.....0005 00
 Operation In Unusual Conditions.....0006 00
 Operating Procedures.....0005 00
 Operator Services.....0010 00

P

Pamphlets.....0028 00
 Part Number Index.....0046 00
 Preparation For Movement.....0005 00
 Preparation For Storage or Shipment.....0018 00
 Preventive Maintenance Checks And Services (PMCS).....0010 00

Q

Quality Deficiency Report0028 00

R

References0028 00
Remarks For SHS.....0029 00
Repair Parts and Special Tools List0030 00
Reporting Equipment Improvement Recommendations (EIRs)0001 00
Reporting Errors and Recommending Improvements0028 00

S

Safety, Care And Handling, Warnings, Cautions And Notes0001 00
Service upon Receipt.....0012 00
Siting Requirements0005 00

T

Table of Contentsi
Technical Manuals.....0028 00
Theory Of Operation.....0003 00
Tools And Test Equipment Requirements0029 00
Troubleshooting Procedures, Operator0009 00
Troubleshooting Procedures, Unit.....0019 00

U

Unit Maintenance Procedures0019 00
Unpacking.....0005 00
Usable On Code0030 00

V

W

Warningsa

THIS PAGE INTENTIONALLY LEFT BLANK

By Order of the Secretary of the Army:

Official:



JOEL B. HUDSON

*Administrative Assistant to the
Secretary of the Army*

0128507

ERIC K. SHINSEKI
*General, United States Army
Chief of Staff*

DISTRIBUTION:

To be distributed in accordance with Initial Distribution Number (IDN) 256699, requirements for TM 10-4520-263-12&P.

THIS PAGE INTENTIONALLY LEFT BLANK

These are the instructions for sending an electronic 2028

The following format must be used if submitting an electronic 2028. The subject line must be exactly the same and all fields must be included; however only the following fields are mandatory: 1, 3, 4, 5, 6, 7, 8, 9, 10, 13, 15, 16, 17, and 27.

From: "Whomever" <whomever@avma27.army.mil>

To: amssb-rim-e@natick.army.mil

Subject: DA Form 2028

1. **From:** Joe Smith
2. **Unit:** home
3. **Address:** 4300 Park
4. **City:** Hometown
5. **St:** MO
6. **Zip:** 77777
7. **Date Sent:** 19-OCT-93
8. **Pub no:** 55-2840-229-23
9. **Pub Title:** TM
10. **Publication Date:** 04-JUL-85
11. **Change Number:** 7
12. **Submitter Rank:** MSG
13. **Submitter FName:** Joe
14. **Submitter MName:** T
15. **Submitter LName:** Smith
16. **Submitter Phone:** 123-123-1234
17. **Problem:** 1
18. **Page:** 2
19. **Paragraph:** 3
20. **Line:** 4
21. **NSN:** 5
22. **Reference:** 6
23. **Figure:** 7
24. **Table:** 8
25. **Item:** 9
26. **Total:** 123
27. **Text:**

This is the text for the problem below line 27.

THIS PAGE INTENTIONALLY LEFT BLANK

RECOMMENDED CHANGES TO EQUIPMENT TECHNICAL PUBLICATIONS



THEN ...JOT DOWN THE DOPE ABOUT IT ON THIS FORM, CAREFULLY TEAR IT OUT, FOLD IT AND DROP IT IN THE MAIL!

SOMETHING WRONG WITH THIS PUBLICATION?

FROM: (PRINT YOUR UNIT'S COMPLETE ADDRESS)
 PFC John DOE
 Co A 3rd Engineer Bn
 Ft. Leonardwood, MO 63108

DATE SENT
 22 August 1992

PUBLICATION NUMBER: TM 1-1520-250-10
 PUBLICATION DATE: 15 June 1992
 PUBLICATION TITLE: Operator's manual MH60K Helicopter

BE EXACT PIN-POINT WHERE IT IS				IN THIS SPACE, TELL WHAT IS WRONG AND WHAT SHOULD BE DONE ABOUT IT:
PAGE NO	PARA-GRAPH	FIGURE NO	TABLE NO	
6	2-1 a			In line 6 of paragraph 2-1a the manual states the engine has 6 cylinders. The engine on my set only has 4 cylinders. Change the manual to show 4 cylinders.
B1		4-3		Callout 16 in figure 4-3 is pointed at a bolt. In key to figure 4-3, item 16 is called a shim. Please correct one or the other

PRINTED NAME, GRADE OR TITLE, AND TELEPHONE NUMBER: JOHN DOE, PFC (268) 317-7111

SIGN HERE: JOHN DOE *John Doe*

DA FORM 2028-2
 1 JUL 79

PREVIOUS EDITIONS ARE OBSOLETE.
 DRSTS-M verprint2, 1 Nov 80

P.S. - IF YOUR OUTFIT WANTS TO KNOW ABOUT YOUR RECOMMENDATION, MAKE A CARBON COPY OF THIS AND GIVE TO YOUR HEADQUARTERS.

FILL IN YOUR
UNITS ADDRESS



FOLD BACK

DEPARTMENT OF THE ARMY

OFFICIAL BUSINESS

COMMANDER
U.S. ARMY SOLDIER AND BIOLOGICAL CHEMICAL COMMAND
ATTN: AMSSB-RIM-E
KANSAS STREET
NATICK, MA 01760-5052

TEAR ALONG PERFORATED LINE

FILL IN YOUR
UNITS ADDRESS



FOLD BACK

DEPARTMENT OF THE ARMY

OFFICIAL BUSINESS

COMMANDER
U.S. ARMY SOLDIER AND BIOLOGICAL CHEMICAL COMMAND
ATTN: AMSSB-RIM-E
KANSAS STREET
NATICK, MA 01760-5052

TEAR ALONG PERFORATED LINE

FILL IN YOUR
UNITS ADDRESS



FOLD BACK

DEPARTMENT OF THE ARMY

OFFICIAL BUSINESS

COMMANDER
U.S. ARMY SOLDIER AND BIOLOGICAL CHEMICAL COMMAND
ATTN: AMSSB-RIM-E
KANSAS STREET
NATICK, MA 01760-5052

TEAR ALONG PERFORATED LINE

FILL IN YOUR
UNITS ADDRESS



FOLD BACK

DEPARTMENT OF THE ARMY

OFFICIAL BUSINESS

COMMANDER
U.S. ARMY SOLDIER AND BIOLOGICAL CHEMICAL COMMAND
ATTN: AMSSB-RIM-E
KANSAS STREET
NATICK, MA 01760-5052

TEAR ALONG PERFORATED LINE

FILL IN YOUR
UNITS ADDRESS



FOLD BACK

DEPARTMENT OF THE ARMY

OFFICIAL BUSINESS

COMMANDER
U.S. ARMY SOLDIER AND BIOLOGICAL CHEMICAL COMMAND
ATTN: AMSSB-RIM-E
KANSAS STREET
NATICK, MA 01760-5052

TEAR ALONG PERFORATED LINE

The Metric System and Equivalents

Linear Measure

1 centimeter = 10 millimeters = .39 inch
 1 decimeter = 10 centimeters = 3.94 inches
 1 meter = 10 decimeters = 39.37 inches
 1 dekameter = 10 meters = 32.8 feet
 1 hectometer = 10 dekameters = 328.08 feet
 1 kilometer = 10 hectometers = 3,280.8 feet

Weights

1 centigram = 10 milligrams = .15 grain
 1 decigram = 10 centigrams = 1.54 grains
 1 gram = 10 decigrams = .035 ounce
 1 dekagram = 10 grams = .35 ounce
 1 hectogram = 10 dekagrams = 3.52 ounces
 1 kilogram = 10 hectograms = 2.2 pounds
 1 quintal = 100 kilograms = 220.46 pounds
 1 metric ton = 10 quintals = 1.1 short tons

Liquid Measure

1 centiliter = 10 milliliters = .34 fl. ounce
 1 deciliter = 10 centiliters = 3.38 fl. ounces
 1 liter = 10 deciliters = 33.81 fl. ounces
 1 dekaliter = 10 liters = 2.64 gallons
 1 hectoliter = 10 dekaliters = 26.42 gallons
 1 kiloliter = 10 hectoliters = 264.18 gallons

Square Measure

1 sq. centimeter = 100 sq. millimeters = .155 sq. inch
 1 sq. decimeter = 100 sq. centimeters = 15.5 sq. inches
 1 sq. meter (centare) = 100 sq. decimeters = 10.76 sq. feet
 1 sq. dekameter (are) = 100 sq. meters = 1,076.4 sq. feet
 1 sq. hectometer (hectare) = 100 sq. dekameters = 2.47 acres
 1 sq. kilometer = 100 sq. hectometers = .386 sq. mile

Cubic Measure

1 cu. centimeter = 1000 cu. millimeters = .06 cu. inch
 1 cu. decimeter = 1000 cu. centimeters = 61.02 cu. inches
 1 cu. meter = 1000 cu. decimeters = 35.31 feet

Approximate Conversion Factors

<i>To change</i>	<i>To</i>	<i>Multiply by</i>	<i>To change</i>	<i>To</i>	<i>Multiply by</i>
inches	centimeters	2.540	ounce-inches	newton-meters	.007062
feet	meters	.305	centimeters	inches	.394
yards	meters	.914	meters	feet	3.280
miles	kilometers	1.609	meters	yards	1.094
square inches	square centimeters	6.451	kilometers	miles	.621
square feet	square meters	.093	square centimeters	square inches	.155
square yards	square meters	.836	square meters	square feet	10.764
square miles	square kilometers	2.590	square meters	square yards	1.196
acres	square hectometers	.405	square kilometers	square miles	.386
cubic feet	cubic meters	.028	square hectometers	acres	2.471
cubic yards	cubic meters	.765	cubic meters	cubic feet	35.315
fluid ounces	milliliters	29.573	cubic meters	cubic yards	1.308
pints	liters	.473	milliliters	fluid ounces	.034
quarts	liters	.946	liters	pints	2.113
gallons	liters	3.785	liters	quarts	1.057
ounces	grams	28.349	liters	gallons	.264
pounds	kilograms	.454	grams	ounces	.035
short tons	metric tons	.907	kilograms	pounds	2.205
pound-feet	newton-meters	1.356	metric tons	short tons	1.102
pound-inches	newton-meters	.11296			

Temperature (Exact)

_F	Fahrenheit temperature	5/9 (after subtracting 32)	Celsius temperature	_C
----	---------------------------	-------------------------------	------------------------	----

PIN: 079344-000